

VERTICAL ACID ALKALINE RESISTANT PUMP 可空轉直立式耐酸鹼泵浦

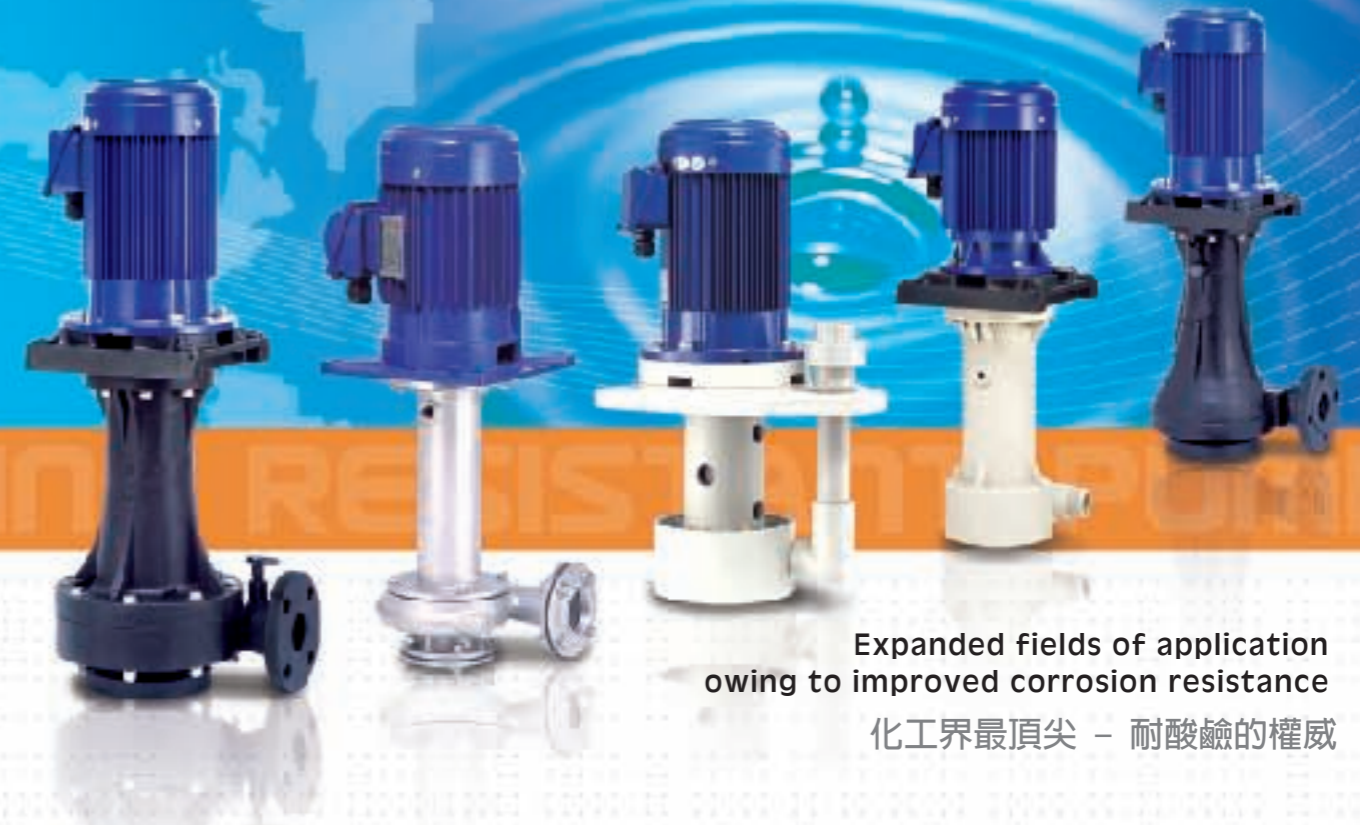

Expanded fields of application
owing to improved corrosion resistance

化工界最頂尖 – 耐酸鹼的權威



日 益 電 機 股 份 有 限 公 司
國 寶 開 發 實 業 有 限 公 司
日 勝 科 技 有 限 公 司

ZI YI ELECTRICAL ENGINEERING CO., LTD.
KUOB AO DEVELOPMENT AND ENT CO., LTD.
ZI SHENG TECHNOLOGICAL CO., LTD.

總公司：台灣省台中縣烏日鄉大同五街31號
HEAD OFFICE: NO. 31 Da Tong Str. Wu Zi Village 414,
Taichung County, Taiwan
工廠：台灣省台中縣烏日鄉五光路746巷28號
FACTORY: NO.28, Lane 746, Wuguang Rd., Wu Zi Village 414,
Taichung County, Taiwan
TEL: 886-4-23384262 / 23389123 / 23384675 / 23384142
FAX: 886-4-23375335

北區分公司：台灣省桃園縣龜山鄉忠義路三段199號D棟
TEL: 886-3-3270698 / 3270699 / 3270700
FAX: 886-3-3270697
E-mail: kuobao@so-net.net.tw
http://www.kuobao-intl.com.tw

日 益 電 機 (昆 山) 有 限 公 司

昆山廠：江蘇省昆山市石牌鎮中華路北側
TEL: 0512-57688841~2 FAX: 0512-57688843

日 益 電 機 (東 莞) 有 限 公 司

廣東廠：廣東省東莞市沙田鎮穗豐年村秋盛工業區
TEL: 0769-88681901~2 / 88687791~3 / 88806781~3
FAX: 0769-88681903

泉州服務站：福建省泉州市清濂工業區德泰路建龍花園B棟303室
TEL: 13960288782 FAX: 0595-22493903

溫嶺服務站：浙江省溫嶺市大溪鎮鴻溪花園20幢-單元102室
TEL: 13957733026 FAX: 0576-86180967

寧波服務站：浙江省寧波市滄海路2068弄2號1606室
TEL: 13805862662 FAX: 0574-87928653

天津服務站：天津市北辰區辰昌路3號延長線富山花園8幢2號門102室
TEL: 13820276566 FAX: 022-26679510

※ 版權所有 翻印必究 ※

DE 得獎廣告 CT1200810 1000



化工界最頂尖-耐酸鹼的權威

www.KUOBAO-intl.com.tw



A new level of pump performance.

展現泵浦性能新境界

日益電機(股)公司秉持“創新突破、技術領先”的理念，矢志鑽研泵浦性能及化學成分，經過專業設計，開發製造各式耐酸鹼泵浦，憑著卓越傑出的經驗與理論基礎，日益電機(股)公司將為您提供創新信賴的泵浦，滿足您不同的使用需求。

日益電機(股)公司自創立以來，不斷致力於市場的拓展，多年來對於國際市場的努力耕耘，目前已在國際市場上建立綿密的行銷據點，受到國際客戶的一致推崇，日益電機(股)公司誓要成為品質卓越、世界第一的泵浦新典範。

日益電機(股)公司生產之泵浦，永遠朝高標準、高性能、高品質的目標邁進，全系列機種已通過CE認證。



Based on the company's philosophy of "Innovative Design, Technology Leadership", Zi Yi is totally dedicated to the research of pump performance and chemical composition. For over years we have designed and manufactured a wide range of acid/alkaline resistant pumps. Based on our extensive experience combined with theoretical basis, Zi Yi will provide you the innovative and dependable pumps to meet your specific applications.

Since the company established, Zi Yi has spent great efforts in developing global market. Through the years of efforts, Zi Yi has set up a comprehensive sales networks around the world. Zi Yi pumps have been fully satisfied to all customers. Look to future, Zi Yi will keep moving toward the target of becoming a world class pump manufacturer.

Zi Yi is always devoted to manufacture pumps which are high standard, high performance and high quality for the purpose of satisfying customer needs. All series of pump have been successfully patented CE certification

Expanded fields of application owing to improved corrosion resistance...



▶ 專業顧問

專業泵浦選型諮詢，日益電機(股)公司提供最適材質及最佳性能的泵浦給客戶，讓客戶更能了解及滿足自己的需求。

▶ 創新研發

日益電機(股)公司擁有堅強的研發陣容，追求創新技術的執著精神，不斷改進泵浦性能，以求在市場上提供更加優質的產品。

▶ 技術領先

豐富的生產經驗，配合渾厚的專業技術，日益電機(股)公司不斷生產製造出應用範圍最廣泛的耐酸鹼泵浦。

▶ 品質卓越

嚴格的品質制度，是日益電機(股)公司的一貫傳統，每一台泵浦在出廠前，都需經過嚴格的品質檢驗，包括泵浦性能、壓力、水量及測漏等重重試驗，以確保日益電機(股)公司生產的優異品質。

▶ 服務至上

日益電機(股)公司有效率的組織與生產流程，能快速交貨給客戶，並提供最快速、最可信賴的售後服務，不論是在出貨前後都能讓客戶大大滿意。

▶ PROFESSIONAL CONSULTANCY

Zi Yi engineers are ready to help you to select the correct models of pump. Zi Yi provides the most suitable pump materials and the best possible pumps to fully meet your requirements.

▶ INNOVATIVE R&D

At Zi Yi we have outstanding R&D team who are dedicated to pursuing the new technology. In addition, our R&D engineers constantly improve pump performance to provide the best quality pumps for our customers.

▶ TECHNOLOGY LEADERSHIP

With the extensive manufacturing experience and professional technology background, Zi Yi offers the most comprehensive range of acid/alkaline resistant pump.

▶ SUPERIOR QUALITY

Rigorous quality control is a tradition at Zi Yi. Each pump is subject to rigorous quality inspection prior to shipment. The comprehensive tests include pump performance, pressure, flow and leakage, etc. All these tests will ensure the maximum dependability for each pump from Zi Yi.

▶ FOREMOST SERVICE

Zi Yi's efficient company organization and production process ensure prompt delivery. Furthermore we also offer the efficient and dependable services before and after sales.

可空轉直立式耐酸鹼泵浦

DRY RUN & VERTICAL ACID / ALKALINE RESISTANT PUMP

槽内外式 IN & OUT-TANK TYPE

KD series



馬力 POWER:1~15HP

KDH series



馬力 POWER:3~10HP

不鏽鋼材質 STAINLESS

KDS series



馬力 POWER:1/2~5HP

化學氣體乾式液封

馬達運轉時其離心力促使液封自動張開，形成運轉中無摩擦點之狀態。而馬達停止運轉時，離心力消失後液封本身之彈性自動彈回密封，阻擋化學氣上升，在液封上面還有油封保護裝置，這兩種裝置形成雙重保護，可確保防止馬達及軸承被化學氣體浸蝕，延長馬達及泵浦之使用壽命。

CHEMICAL VAPOR AND DRY VAPOR SEAL

When the motor is operating, the lid of the vapor seal is forced open by centrifugal force, thus no friction results. Once the motor stops, the lid bounces back to completely stop any leakage of chemical vapor. Moreover, the oil seal, which is located above the vapor seal, can protect the motor and bearing against chemical corrosion and can prolong the used life of the motor and pump.

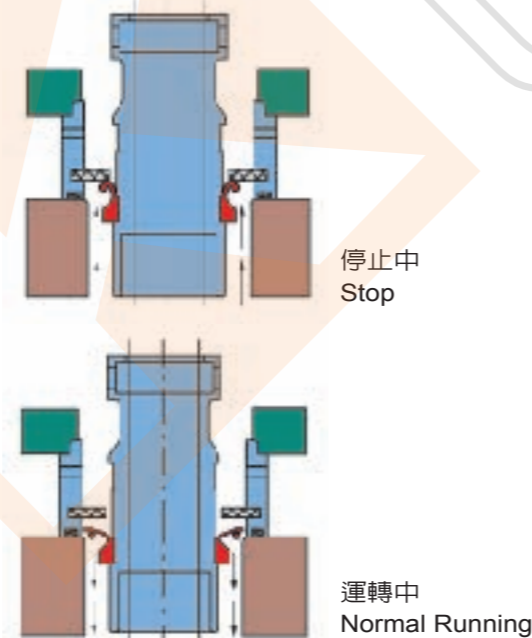

槽内式 IN-TANK TYPE

KPT series



馬力 POWER:2~5HP

KDV series



馬力 POWER:1/2~10HP

KP series



馬力 POWER:1/15~2HP

型號說明 MODEL IDENTIFICATION

KD - 50 - VK - 5 - 6 - V - F - B

1 2 3 4 5 6 7 8

- | | | | | | | |
|-----------------------|--|--------------------------------|---------|----------|----------|----------------------------|
| 1. 機型編號 MODEL | : KD | KDV | KPT | KP | KDH | SERIES |
| 2. 口徑 IN-OUTLET | : 15-1/2" | 20-3/4" | 25-1" | 32-1.25" | 40-1.5" | 50-2" 65-2.5" 80-3" 100-4" |
| 3. 比重 SPECIFIC WEIGHT | : VK-1.1 | VP-1.4 | | | | |
| 4. 馬力 POWER | : 1/15 1/8 1/6 1/4 | 1/3 1/2 1 2 3 4 5 7.5 10 15 HP | | | | |
| 5. 頻率 FREQUENCY | : 5-50Hz | 6-60Hz | | | | |
| 6. 橡膠材質 RUBBER | : N-NBR | E-EPDM | V-VITON | T-PTFE | | |
| 7. 泵體材質 MATERIAL | : F-FRPP | C-CFRPP | A-CPVC | P-PVDF | S-SUS316 | |
| 8. 附註 NOTES | : B-採用FRPP材質之馬達連結座(Motor Spacer is FRPP)
H-高揚程(HIGH HEAD) | | | | | |

系列規格 SERIES SPECIFICATIONS

VK / VP TYPE 50Hz

型式 MODEL	曲線 NO	口徑 IN-OUTLET(mm)		馬力 HP	流量 FLOW(L/Min)		揚程 HEAD(M)		重量 Kg
		IN	OUT		VK	VP	VK	VP	
KD-41VK-15	A	50	40	1	175	-	6	-	29
KD-42VK-25	B	50	40	2	190	-	12	-	38
KD-42VK-35	C	50	40	3	270	-	12	-	41
KD-50VK(P)-35	D	65	50	3	330	290	12	12	41
KD-50VK(P)-55	E	65	50	5	470	400	14	14	55
KD-65VK-55	F	80	65	5	500	-	14	-	55
KD-65VK(P)-7.55	G	80	65	7.5	590	500	16	18	95
KD-65VK(P)-105	H	80	65	10	590	570	18	18	106
KD-100VK(P)-155	I	100	80	15	1000	800	27	29	155

性能曲線圖 PERFORMANCE CURVE CHART- 50Hz

▶ KD series

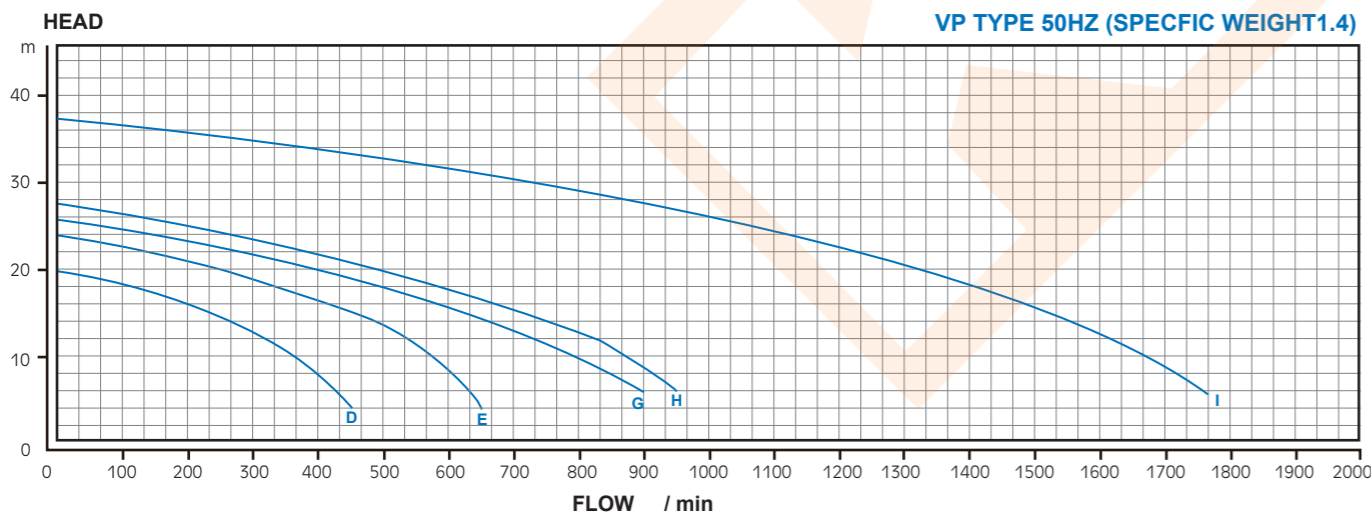
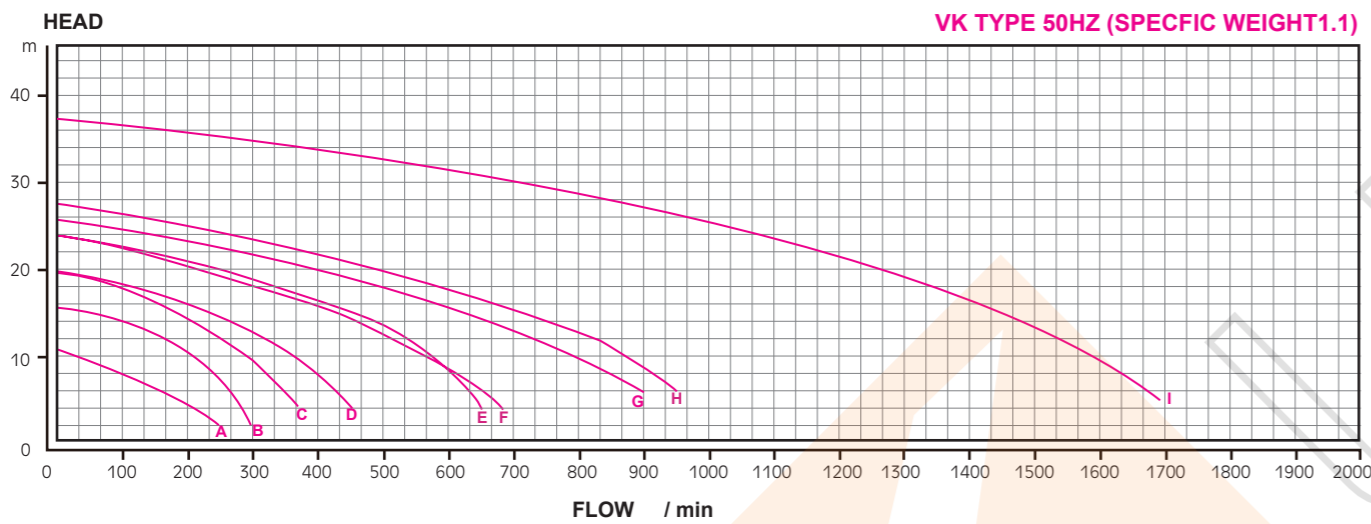

系列規格 SERIES SPECIFICATIONS

VK / VP TYPE 60Hz

型式 MODEL	曲線 NO	口徑 IN-OUTLET(mm)		馬力 HP	流量 FLOW(L/Min)		揚程 HEAD(M)		重量 Kg
		IN	OUT		VK	VP	VK	VP	
KD-41VK-16	a	50	40	1	120	-	8	-	29
KD-42VK-26	b	50	40	2	300	-	10	-	38
KD-42VK-36	c	50	40	3	350	-	14	-	41
KD-50VP-36	d	65	50	3	-	300	-	12	41
KD-50VK(P)-56	e	65	50	5	550	430	15	15	55
KD-65VK-56	f	80	65	5	650	-	15	-	55
KD-65VK(P)-7.56	g	80	65	7.5	780	600	18	16	95
KD-65VK(P)-106	h	80	65	10	890	800	20	18	106
KD-100VK(P)-156	i	100	80	15	1200	1000	25.5	29	155

性能曲線圖 PERFORMANCE CURVE CHART- 60Hz

▶ KD series

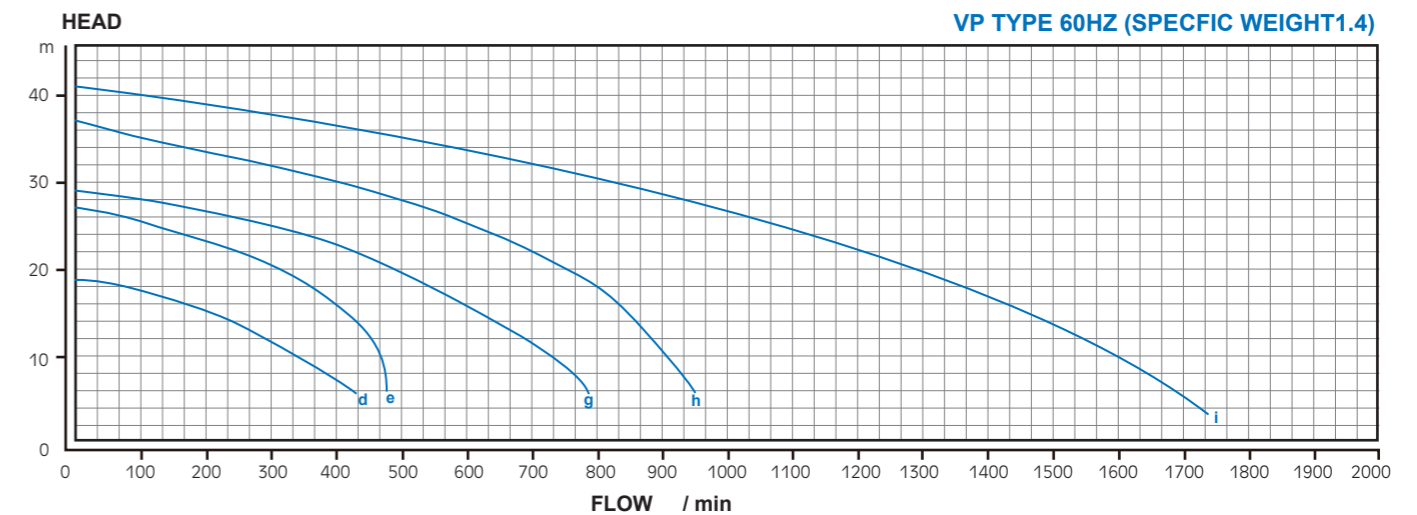
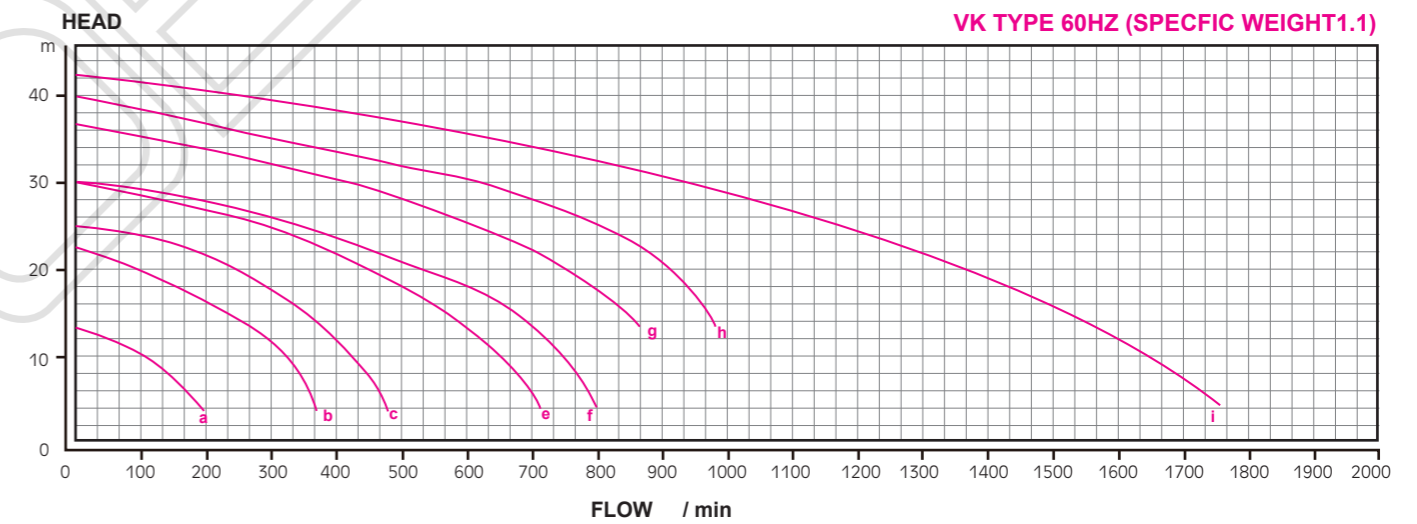

系列規格 SERIES SPECIFICATIONS

VK / VP TYPE 50Hz

型式 MODEL	曲線 NO	口徑 IN-OUTLET(mm)		馬力 HP	流量 FLOW(L/Min)		揚程 HEAD(M)		重量 Kg
		IN	OUT		VK	VP	VK	VP	
KDH-50VK(P)-35	J	65	50	3	350	300	12	12	41
KDH-50VP-55	K	65	50	5	-	400	-	16	55
KDH-65VK-55	L	80	65	5	550	-	15	-	55
KDH-65VK(P)-7.55-H	M	80	65	7.5	400	300	30	28	95
KDH-65VP-105-H	N	80	65	10	-	400	-	30	106
KDS-25VK-1/2	O	25	25	1/2	90	-	13	-	28
KDS-40VK(P)-15	P	40	40	1	240	210	13	11	30
KDS-40VK(P)-25	Q	40	40	2	300	260	15	14	48
KDS-50VK(P)-35	R	50	50	3	400	300	20	17	50
KDS-50VK(P)-55	S	50	50	5	480	420	28	22	55

性能曲線圖 PERFORMANCE CURVE CHART- 50Hz

▶ KDH series

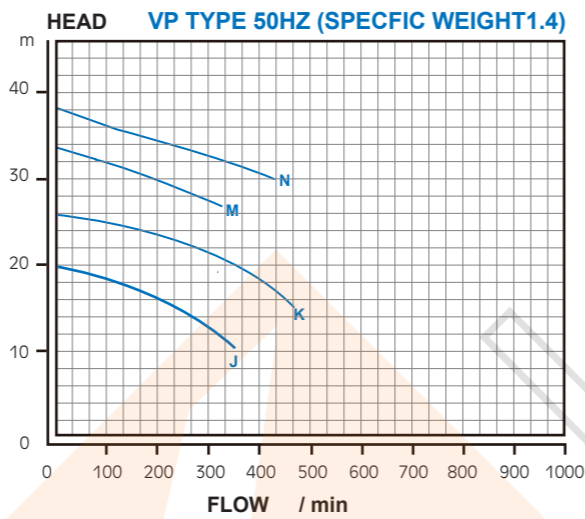
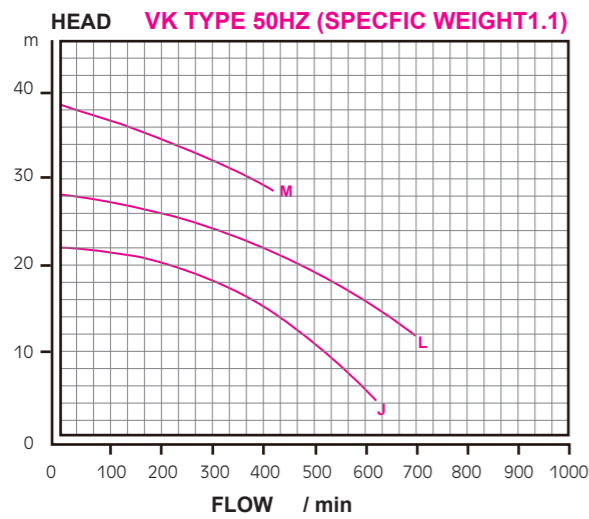

▶ KDS series

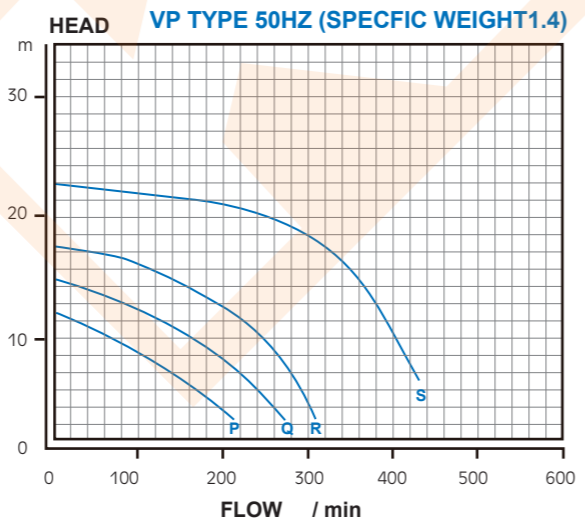
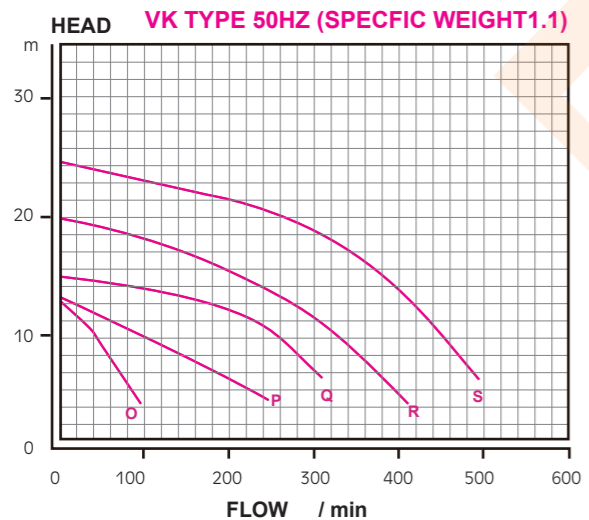

系列規格 SERIES SPECIFICATIONS

VK / VP TYPE 60Hz

型式 MODEL	曲線 NO	口徑 IN-OUTLET(mm)		馬力 HP	流量 FLOW(L/Min)		揚程 HEAD(M)		重量 Kg
		IN	OUT		VK	VP	VK	VP	
KDH-50VK(P)-36	j	65	50	3	350	300	12	12	41
KDH-50VK(P)-56	k	65	50	5	550	400	15	16	55
KDH-65VK-7.56	l	65	80	7.5	600	-	20	-	95
KDH-65VK(P)-7.56-H	m	80	65	7.5	400	300	30	28	95
KDH-65VP-106-H	n	80	65	10	-	400	-	30	106
KDS-25VK-1/2	o	25	25	1/2	80	-	14	-	28
KDS-40VK(P)-16	p	40	40	1	260	160	15	11	30
KDS-40VK(P)-26	q	40	40	2	300	260	17	14	48
KDS-50VK(P)-36	r	50	50	3	350	300	26	19	50
KDS-50VK(P)-56	s	50	50	5	500	450	28	25	55

性能曲線圖 PERFORMANCE CURVE CHART- 60Hz

▶ KDH series

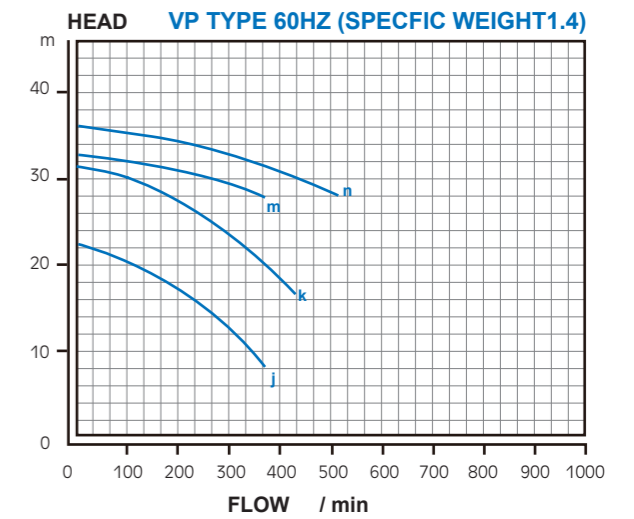
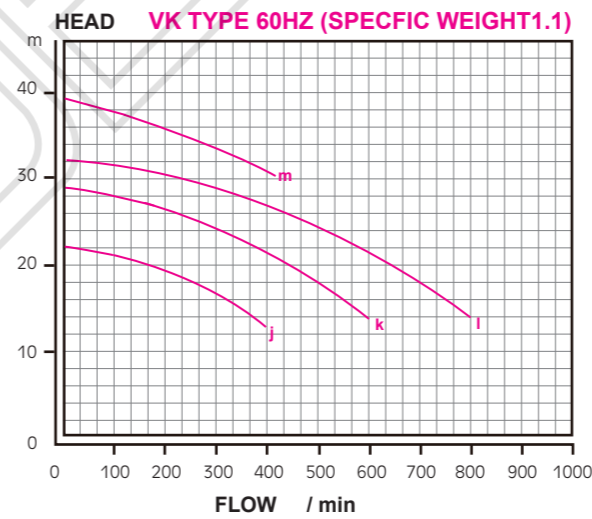

▶ KDS series

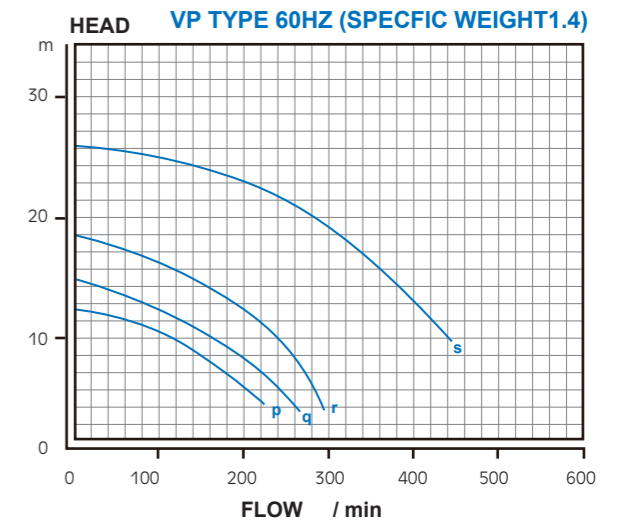
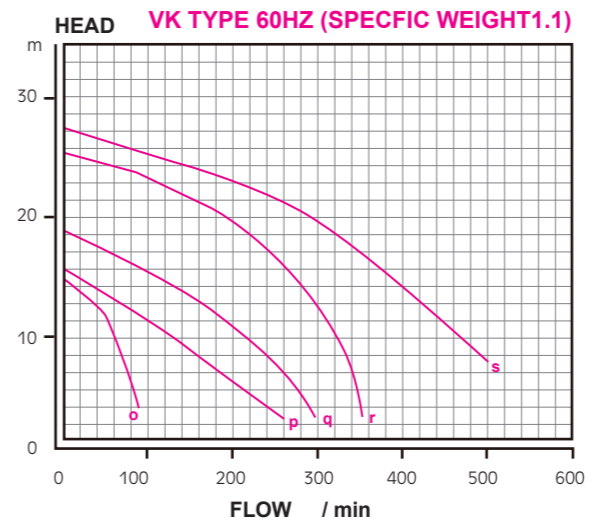

系列規格 SERIES SPECIFICATIONS

VK / VP TYPE 50Hz

型式 MODEL	曲線 NO	口徑		馬力 HP	流量		揚程		重量 Kg
		IN-OUTLET(mm)			FLOW(L/Min)		HEAD(M)		
		IN	OUT		VK	VP	VK	VP	
KP-15VK-1/15	a	20	15	1/15	20	-	0.2	-	3
KP-20VK(P)-1/6	b	25	20	1/6	20	18	2	2	4
KP-20VK-1/4	c	25	20	1/4	50	-	4	-	13
KP-20VK(P)-1/3	d	25	20	1/3	60	50	4	4	13
KP-25VK-1/2	e	40	25	1/2	100	-	5	-	20
KP-25VP-15	f	40	25	1	-	160	-	6	20
KP-40VK(P)-15	g	50	40	1	130	140	8	6	20
KP-40VK(P)-25	h	50	40	2	150	160	10	7	24

性能曲線圖 PERFORMANCE CURVE CHART- 50Hz

➤ KP series

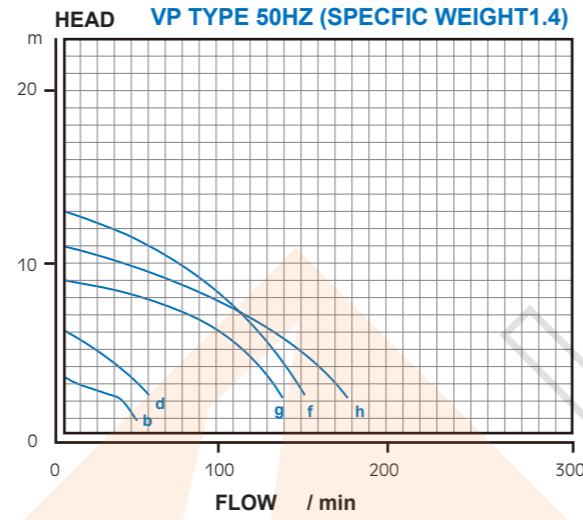
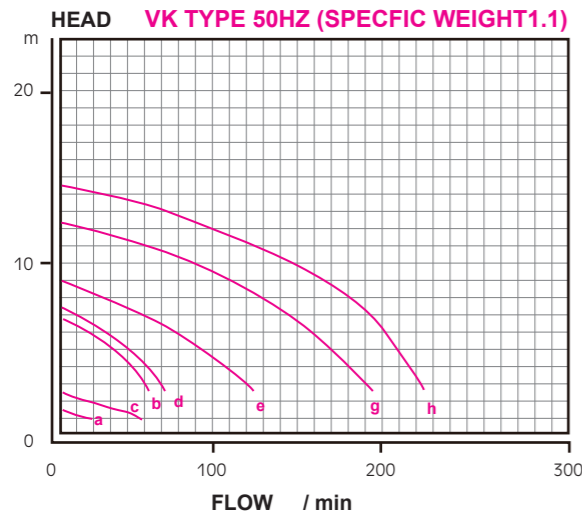

系列規格 SERIES SPECIFICATIONS

VK / VP TYPE 60Hz

型式 MODEL	曲線 NO	口徑		馬力 HP	流量		揚程		重量 Kg
		IN-OUTLET(mm)			FLOW(L/Min)		HEAD(M)		
		IN	OUT		VK	VP	VK	VP	
KP-15VK-1/15	A	20	15	1/15	25	-	0.4	-	3
KP-20VK(P)-1/6	B	25	20	1/6	40	36	2	2	4
KP-20VK-1/4	C	25	20	1/4	60	-	5	-	13
KP-20VK(P)-1/3	D	25	20	1/3	75	60	5	5	13
KP-25VK-1/2	E	40	25	1/2	150	-	4	-	20
KP-25VP-16	F	40	25	1	-	110	-	7	20
KP-40VK(P)-16	G	50	40	1	180	110	6	6	20
KP-40VK(P)-26	H	50	40	2	260	130	10	7	24

性能曲線圖 PERFORMANCE CURVE CHART- 60Hz

➤ KP series

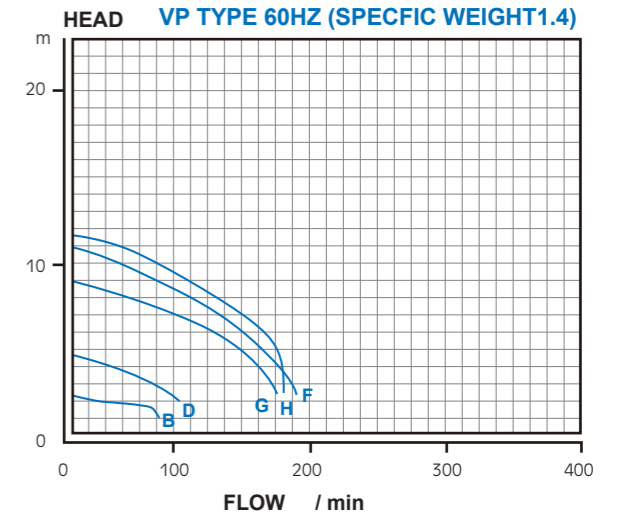
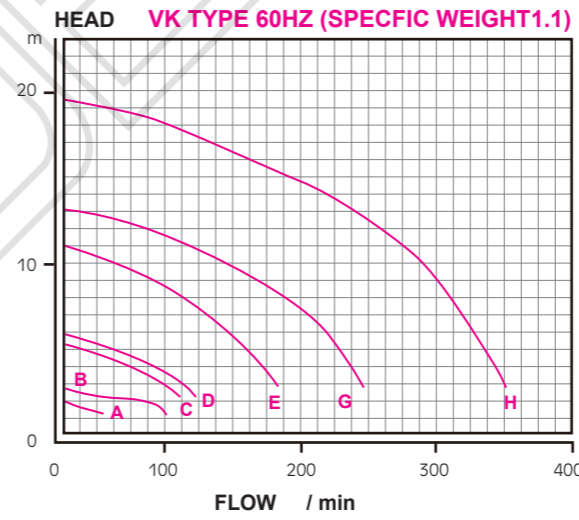

系列規格 SERIES SPECIFICATIONS

VK / VP TYPE 50Hz

型式 MODEL	曲線 NO	口徑 IN-OUTLET(mm)		馬力 HP	流量 FLOW(L/Min)		揚程 HEAD(M)		重量 Kg
		IN	OUT		VK	VP	VK	VP	
KPT-40VK(P)-25	i	50	40	2	180	130	12	8	38
KPT-40VK(P)-35	j	50	40	3	180	200	16	14	40
KPT-40VK(P)-55	k	50	40	5	200	200	16	16	55
KPT-50VK(P)-55	l	50	40	5	200	240	18	16	55
KDV-32VK-1/2	m	40	32	1/2	100	-	7	-	18
KDV-32VK-15	n	40	32	1	100	-	12.5	-	20
KDV-40VK-25	o	50	40	2	200	-	15	-	25
KDV-40VK-35	p	50	40	3	200	-	20.5	-	32
KDV-40VK-45	q	50	40	4	250	-	24	-	35
KDV-40VK-55	r	50	40	5	300	-	28.5	-	40
KDV-50VK-7.55	s	65	50	7.5	400	-	28	-	60
KDV-50VK-105	t	65	50	10	400	-	38	-	72

性能曲線圖 PERFORMANCE CURVE CHART- 50Hz

▶ KPT series

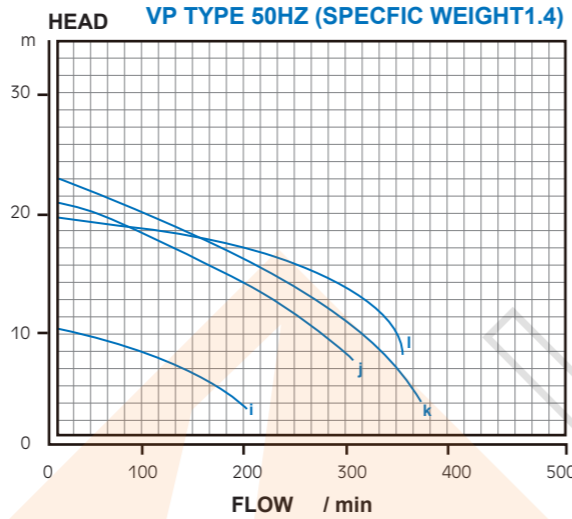
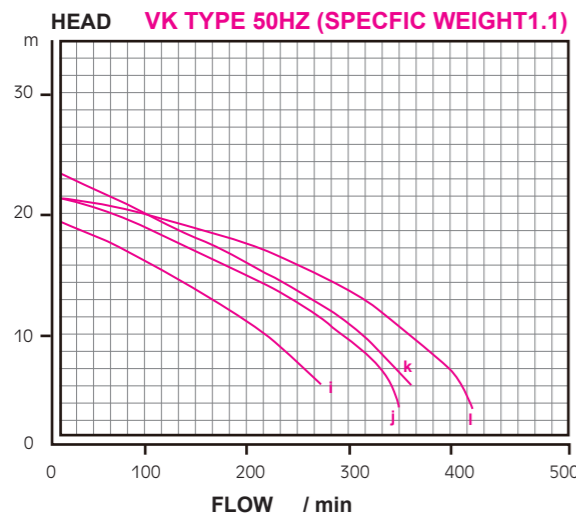

▶ KDV series

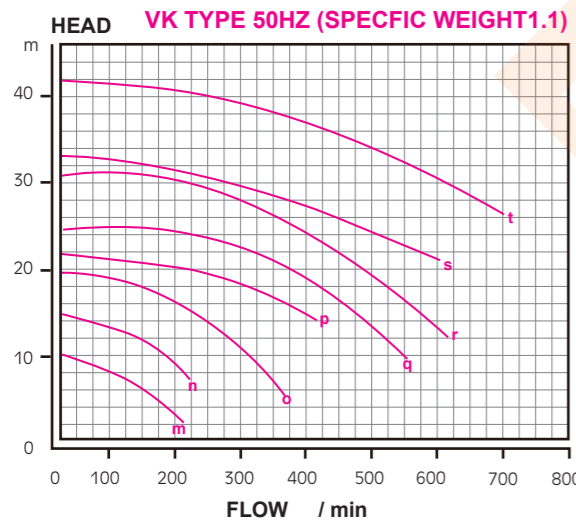

系列規格 SERIES SPECIFICATIONS

VK / VP TYPE 60Hz

型式 MODEL	曲線 NO	口徑 IN-OUTLET(mm)		馬力 HP	流量 FLOW(L/Min)		揚程 HEAD(M)		重量 Kg
		IN	OUT		VK	VP	VK	VP	
KPT-40VK(P)-26	I	50	40	2	210	180	12	12	38
KPT-40VK(P)-36	J	50	40	3	240	160	14	14	40
KPT-40VK(P)-56	K	50	40	5	250	335	18	16	55
KPT-50VP-36	L	50	50	3	-	210	-	16	40
KPT-50VP-56	M	50	50	5	-	290	-	20	55
KDV-32VK-16	N	40	32	1	100	-	10.5	-	20
KDV-40VK-26	O	50	40	2	200	-	14.5	-	25
KDV-40VK-36	P	50	40	3	200	-	20	-	32
KDV-40VK-46	Q	50	40	4	250	-	23.5	-	35
KDV-40VK-56	R	50	40	5	300	-	28.5	-	40
KDV-50VK-7.56	S	65	50	7.5	400	-	28	-	60
KDV-50VK-106	T	65	50	10	400	-	37	-	72

性能曲線圖 PERFORMANCE CURVE CHART- 60Hz

▶ KPT series

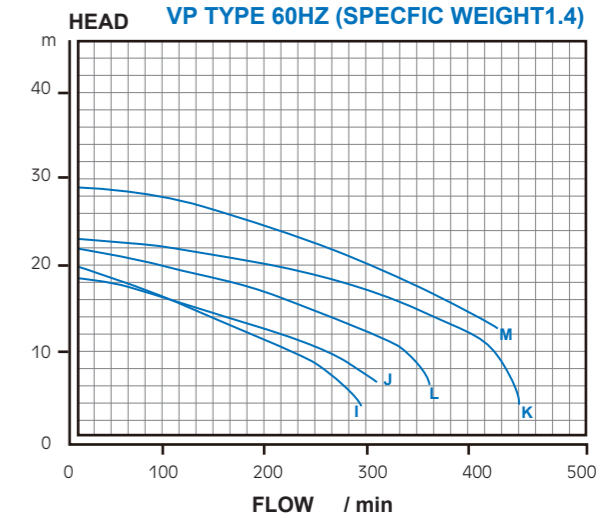
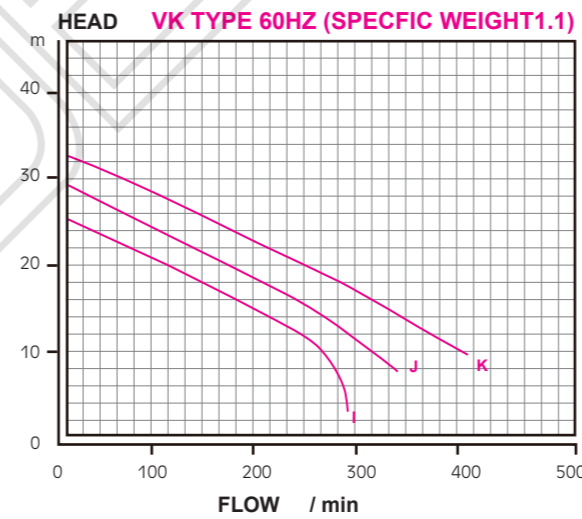

▶ KDV series

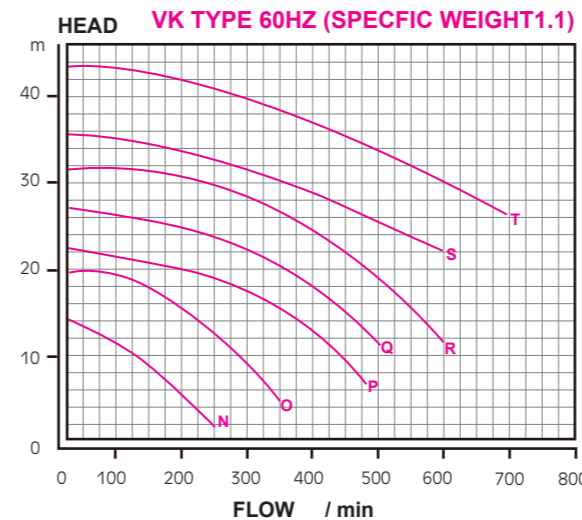

KD 1~5HP

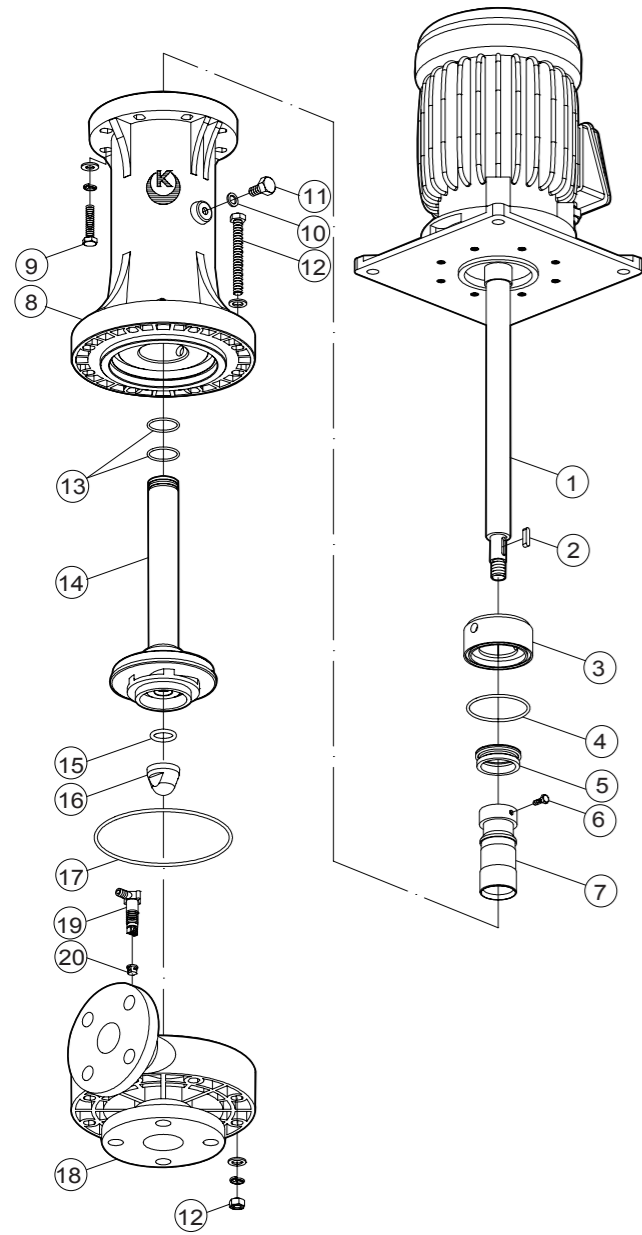

KD 7.5~15HP

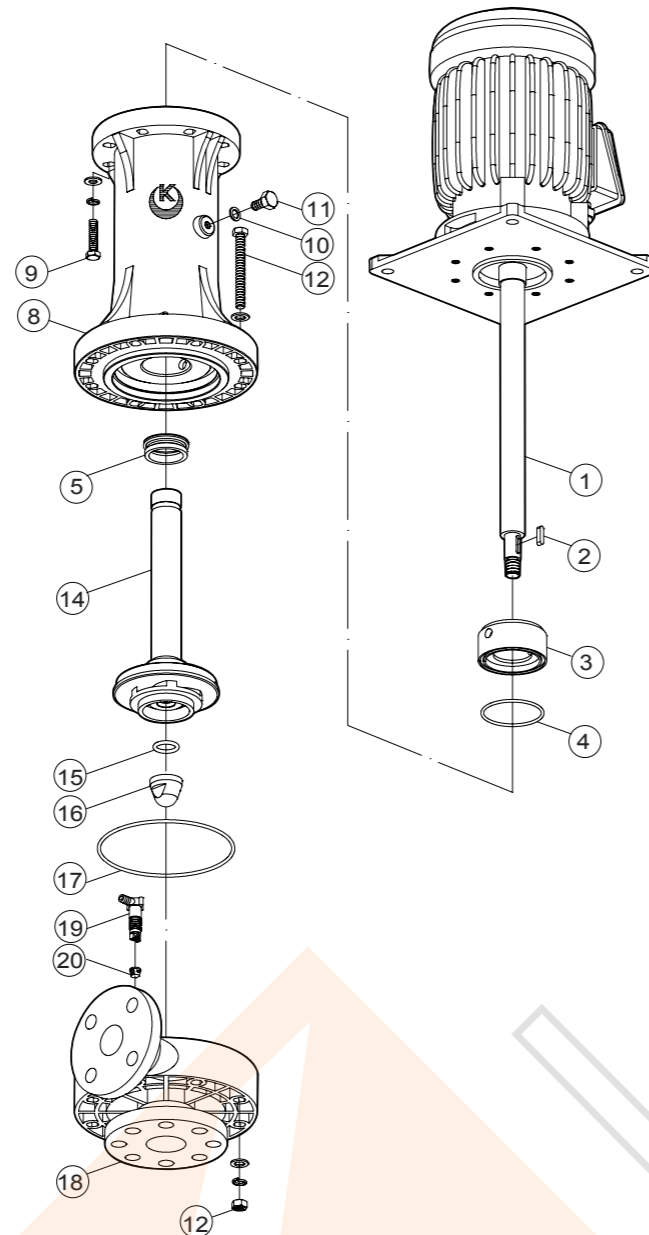

KD-B 1~5HP

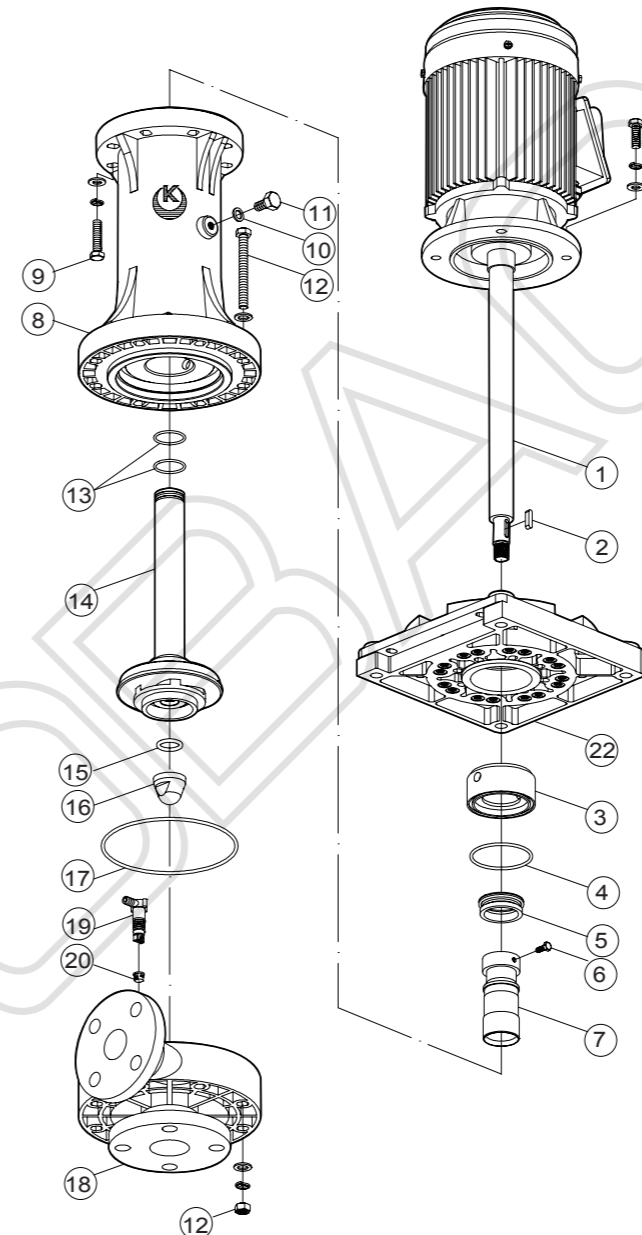

KD-B 7.5~15HP

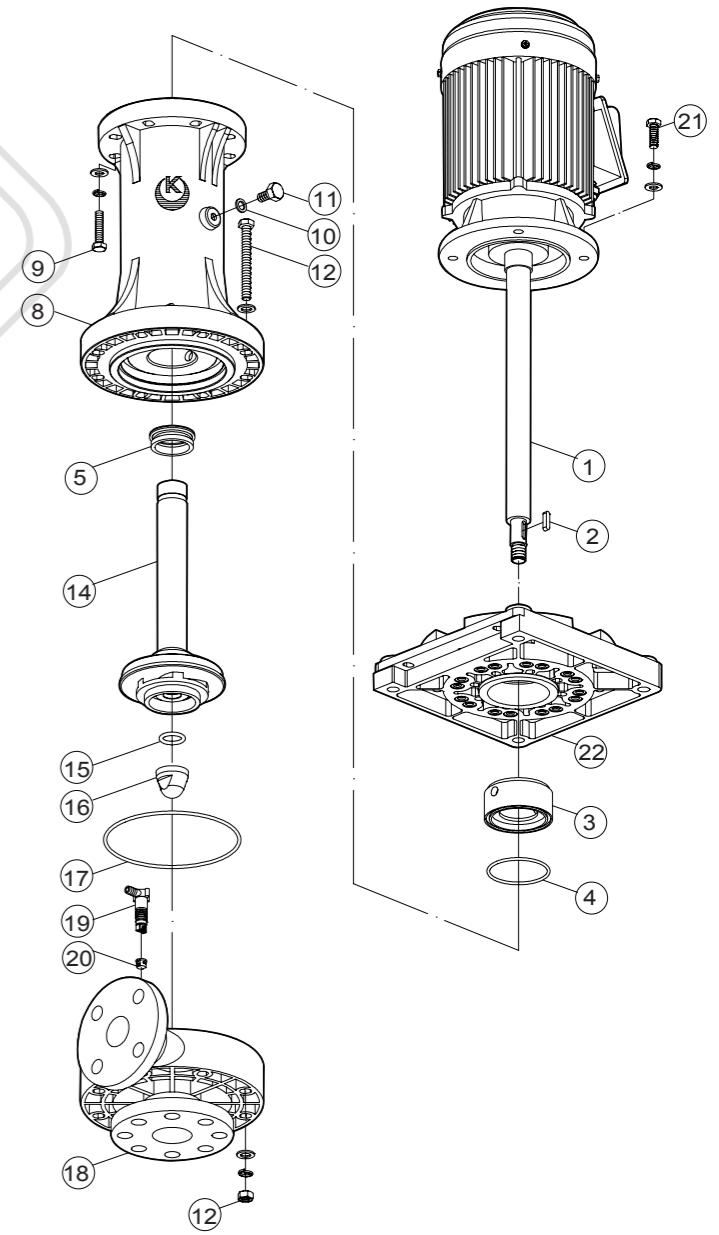

KD 系列特點:

- 最少空氣混合，較大揚程
1. 泵浦本體採用FRPP、CFRPP、CPVC及PVDF材質，□具有耐高溫耐腐蝕之特性。
 2. 乾式液封(1~10HP):可確保防止馬達及軸承被化學氣□體浸蝕，延長馬達及泵浦之使用壽命。
 3. 適用於蝕刻噴洗設備、廢氣洗滌塔、冷卻循環及搭配□□過濾器使用。
 4. 泵浦可無水空轉使用，絕不會損壞。
 5. 用於高腐蝕性藥液及環境下，建議另選購鈦金屬螺□絲，馬達另選購經環氧樹脂塗裝處理，增強耐腐蝕性□及使用壽命。
 6. 創新採用FRPP材質之馬達連結座，相較於傳統FC馬達前托架能大大降低酸氣腐蝕，及機體重量。□

KD SERIES FEATURES:

- The least air mixed and the high head.**
1. Pumps are manufactured from the four materials(FRPP, CFRPP, CPVC, PVDF) to ensure resistance to high heat and corrosion.
 2. Dry Vapor seal (1~10HP): ensure to prevent pumps and bearings form being etched by chemical gas and prolong the using life of pump.
 3. For etching spraying equipments, cooling circulating and be used with filte .
 4. Pumps are no damaged in drying running.
 5. We suggest using Ti screws and painting EPOXY on motors for increasing the corrosion insistence and life of usage in the strong etching chemical solution environment.
 6. Compared to traditional FC motor front cover, motor spacer which is innovatively made of FRPP can dramatically weaken acid corrosion and reduce the weight of machine.

KDH 3~10HP

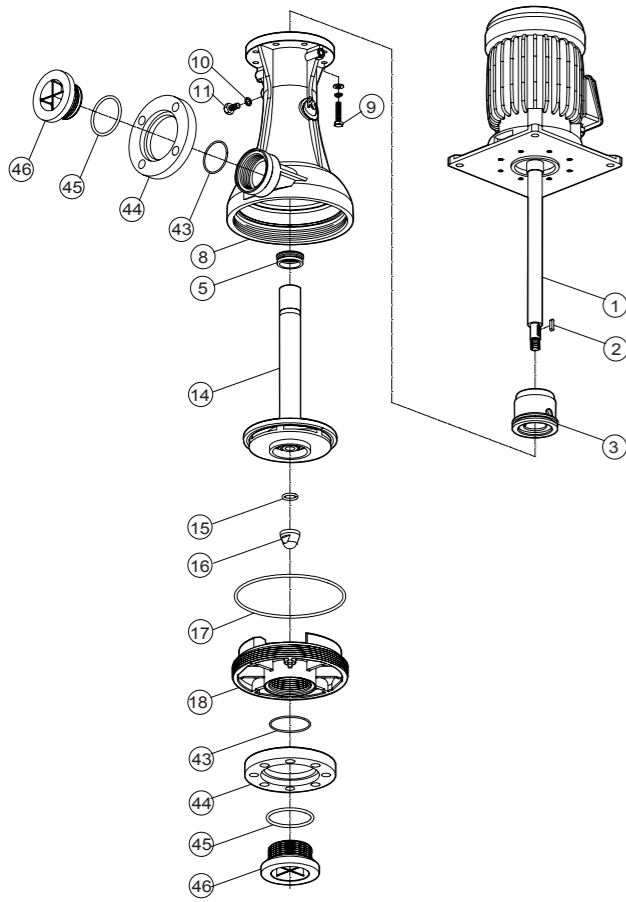

KDH-B 3~10HP

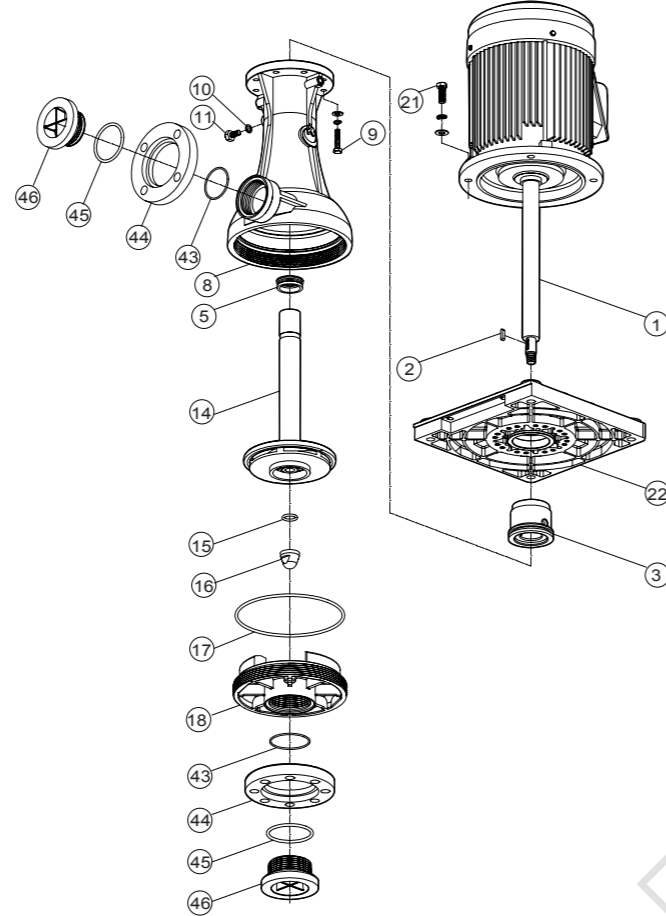

KDH 系列特點:

1. 泵浦本體採用FRPP, CFRPP及 PVDF材質，
□ 具有耐高溫、耐腐蝕之特性。
2. 乾式液封(3~10HP)可確保防止馬達及軸承被化學氣
□ 體浸蝕□延長馬達及泵浦之使用壽命。
3. 適用於蝕刻噴洗設備，廢氣洗滌塔、冷卻循環及搭配
□ 過濾機使用。 □
4. 採無焊接點及出入口為活動式法蘭設計，易於安裝及
□ 日後維修等特性。□
5. 前蓋無螺絲設計，適用於任何環境下使用，獨特具有
□ 高揚程□高壓力 □高效率等特性。
6. 本泵浦可無水空運轉使用，絕不會損壞。
7. 採用高效率鋁合金馬達絕緣等級F級，及創新採用□
□FRPP馬達連結座，不僅大大減輕泵浦機體重量，更能□
□有效防止酸氣侵蝕。

KDH SERIES FEATURES:

1. Pumps are manufactured from the four materials (FRPP, CFRPP, PVDF) to ensure resistance to high heat and corrosion.
2. Dry Vapor seal (3~10HP) : ensure to prevent pumps and bearings from being etched by chemical gas and prolong the using life of pump.
3. For etching spraying equipments, cooling circulating and be used with filte .
4. One piece injected without welding and in-outlet moveable flanges lead us to install and maintain easily.
5. Front covers without screws design have unique high head, high pressure and high eff ciency, and apply to all kinds of environments.
6. Pumps are no damaged in drying running.
7. Due to the effective aluminum motor of insolution class F, and the motor spacer which is innovatively made of FRPP, they make not only the weight of machine lighter but also acid corrosion resistance stronger.

KDS 1/2~2HP

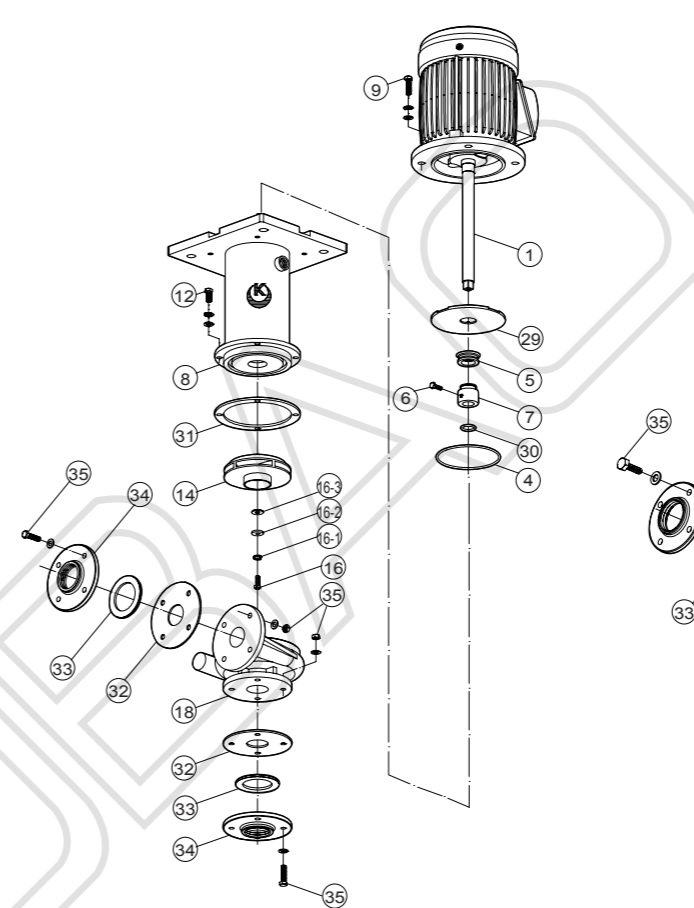

KDS 3~5HP

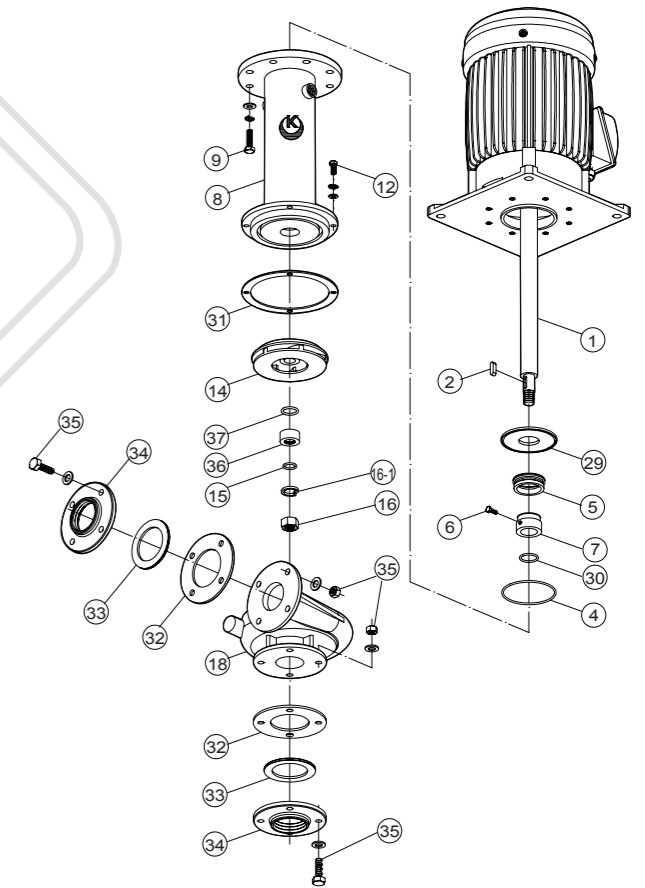

KDS 系列特點:

1. 採用不鏽鋼 316 精密鑄造成型，無砂孔問題，葉輪效
□率。 □
2. 適合各種酸鹼液，循環使用，耐高溫。
3. 無軸封設計，絕不因空運轉而損壞，設計有防止酸氣□
□進入軸承之密封圈，及溢流導溝。
4. 乾式液封可確保防止馬達及軸承被化學氣體侵蝕，延
□長馬達及泵浦之使用壽命。
5. 葉輪經動力平衡校正，低噪音，振動率低。
6. 泵浦體積小，適合槽內槽外設計使用。

KDS SERIES FEATURES:

1. Pumps are cast precisely in stainless steel 316 so that the surface of pumps looks glossy.
2. For all kinds of acid/alkaline solutions, circulating and high temperature assistance.
3. Pumps are no damaged in dry running because of seal-less design, the pumps also are design with vapor seal oring and diversion groove.
4. Dry Vapor seal ensure to prevent pumps and bearings from being etched by chemical gas and prolong the using life of pump.
5. After the correction of dynamical balance, impellers are lower noise and vibrating rate.
6. The volume of pump is so small that it applies to inside and outside of tank.

KP 1/15HP

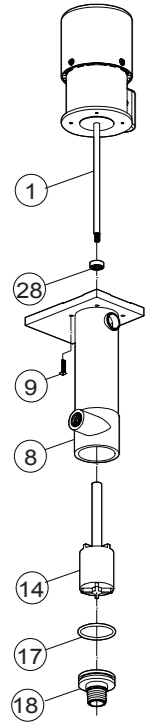

KP 1/6HP

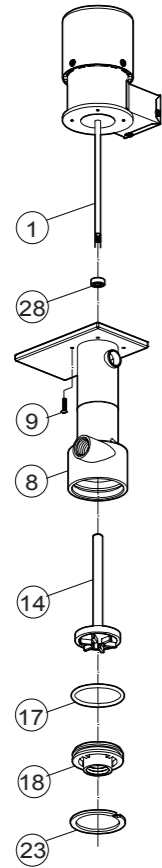

KP 1/4~1/3HP

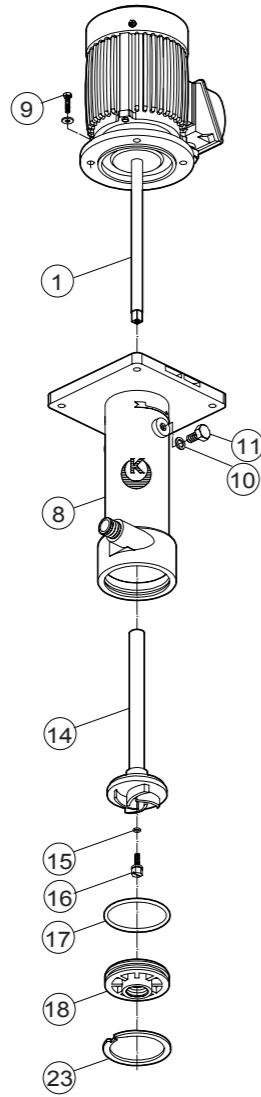

KP 1/2~2HP

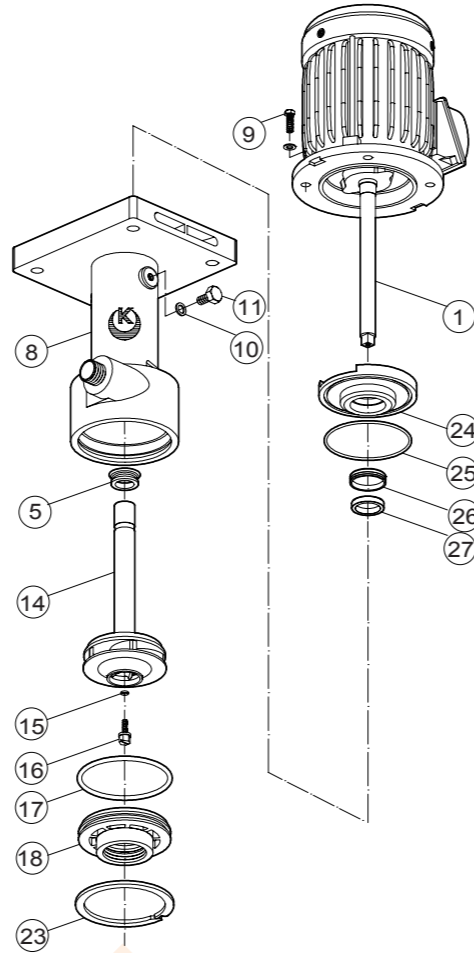

KP 系列特點:

耐腐蝕耐高溫特性

1. 泵浦本體採用FRPP、CFRPP、CPVC及PVDF材質，
□具有耐高溫耐腐蝕之特性
2. 鎖牙式出入口設計，無螺絲，適用於槽內使用
3. 適用於蝕刻噴洗設備、廢氣洗滌塔、冷卻循環及搭配
□過濾器使用
4. 泵浦可無水空轉使用，絕不會損壞

KP SERIES FEATURES:

The characteristics of pumps are durable high temperature and assistant corrosion

1. Pumps are manufactured from the four materials(FRPP, CFRPP, CPVC, PVDF) to ensure resistance to high heat and corrosion.
2. Owing to in-outlet screwed design no screws, the pumps apply to be installed inside of tank.
3. For etching spraying equipments, cooling circulating and be used with filte .
4. Pumps are no damaged in drying running.

KPT 2~5HP

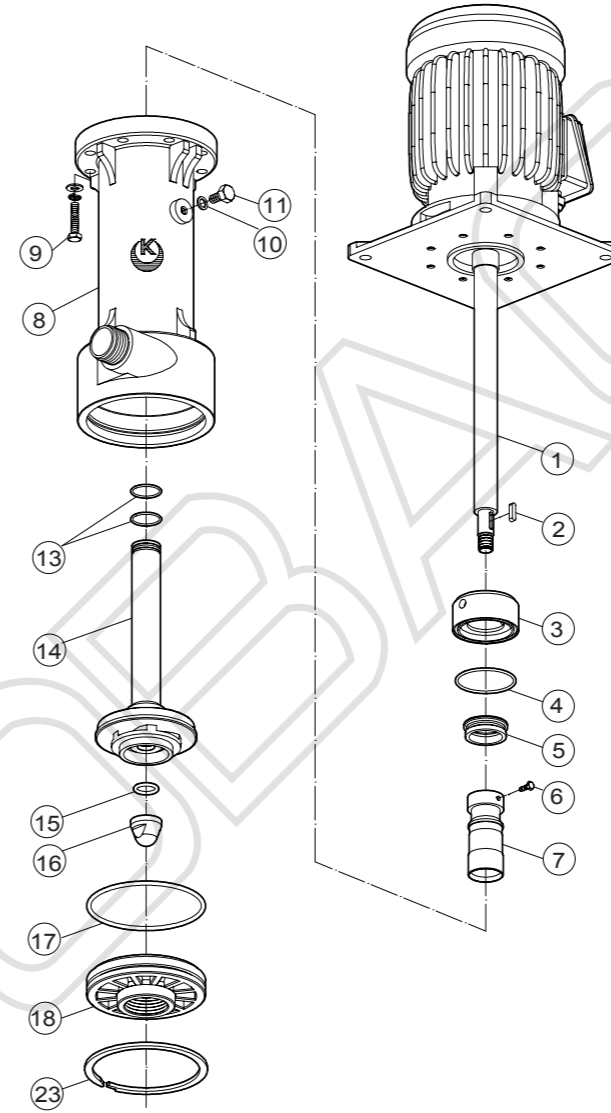

KPT-B 2~5HP

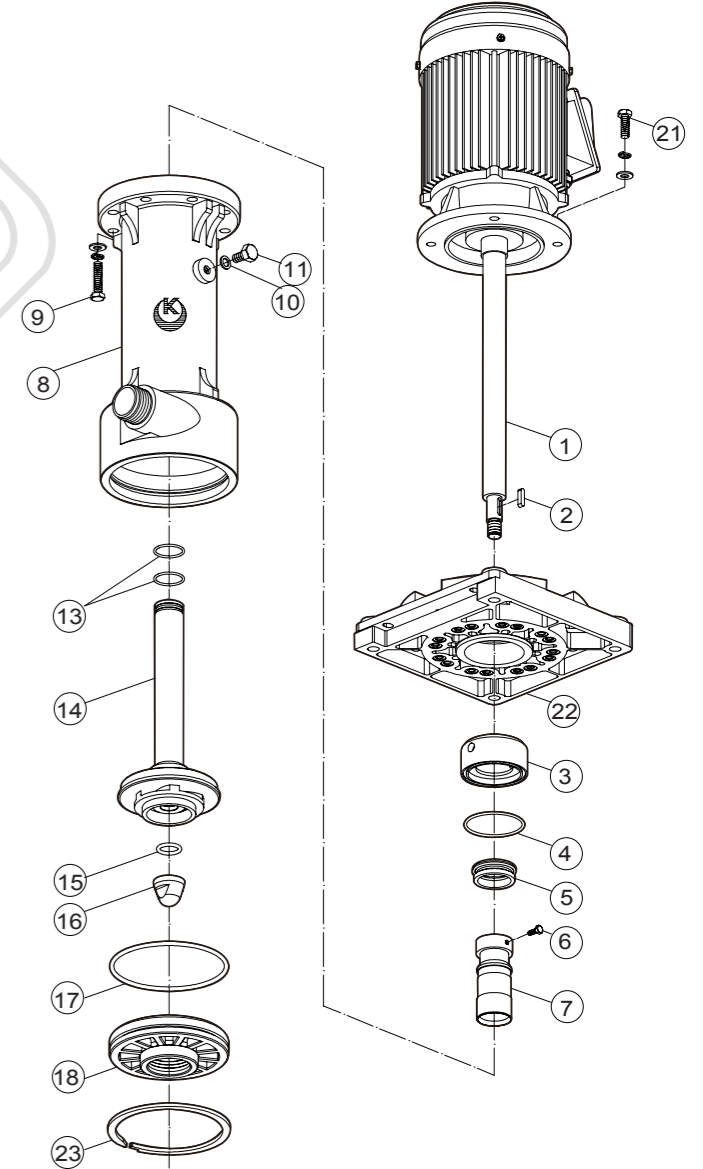

KPT 系列特點:

耐腐蝕耐高溫特性

1. 泵浦本體採用FRPP、CFRPP、CPVC及PVDF材質，
□具有耐高溫耐腐蝕之特性
2. 乾式液封 (2~5HP): 可確保防止馬達及軸承被化學氣體
□浸蝕，延長馬達及泵浦之使用壽命。
3. 鎖牙式出入口設計，無螺絲，適用於槽內使用。
4. 適用於蝕刻噴洗設備，冷卻循環及搭配過濾器使用。
5. 泵浦可無水空運轉使用，絕不會損壞。

KPT SERIES FEATURES:

The characteristics of pumps are durable high temperature and assistant corrosion.

1. Pumps are manufactured from the four materials(FRPP, CFRPP, CPVC, PVDF) to ensure resistance to high heat and corrosion.
2. Dry Vapor seal (2~5HP): ensure to prevent pumps and bearings form being etched by chemical gas and prolong the using life of pump.
3. Pumps apply to be installed inside of tank due to the in-outlet screwed design without screws.
4. For etching spraying equipments, cooling circulating and be used with filte .
5. Pumps are no damaged in drying running.

KDV 1/2~1HP

KDV 2~5HP

KDV 7.5~10HP

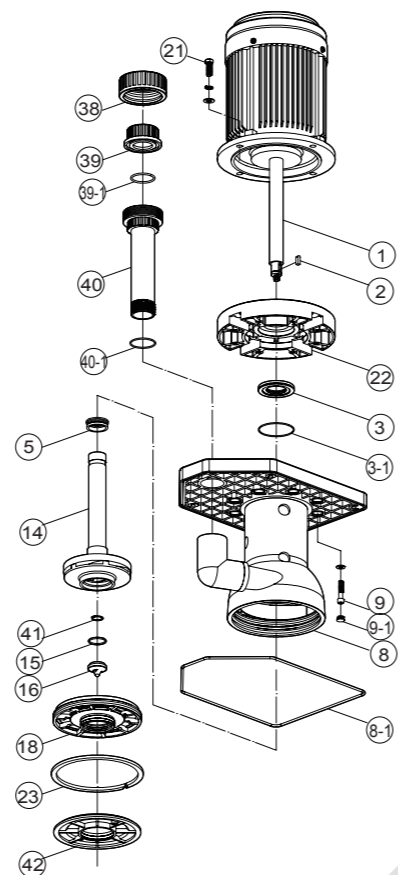
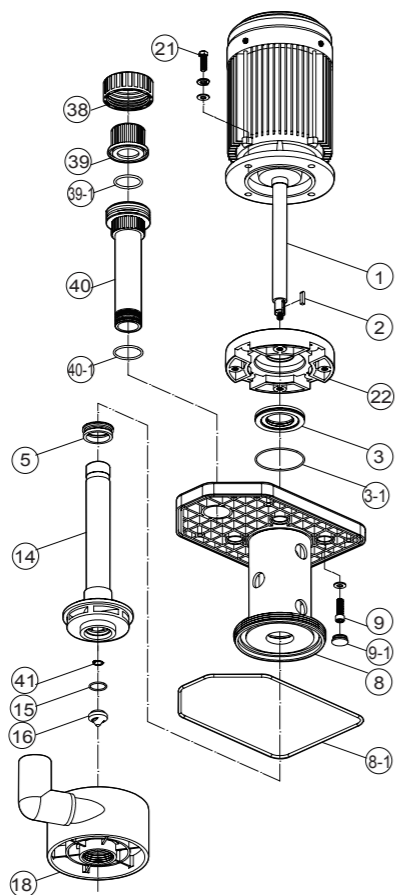
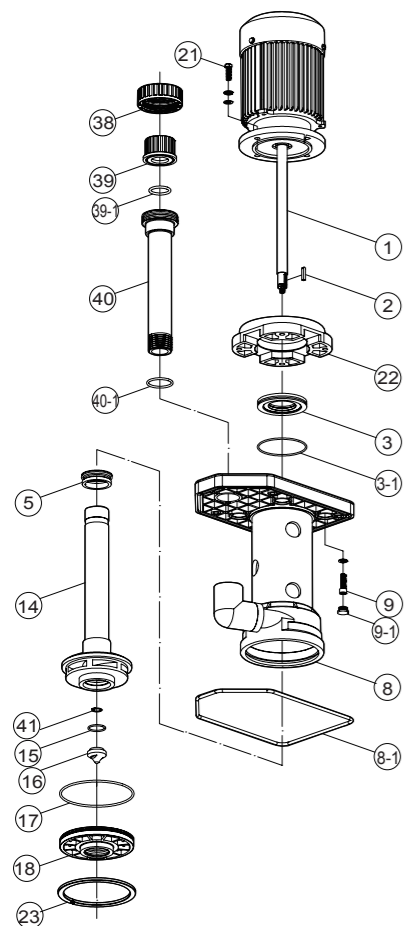

KDV 系列特點:

1. 乾式液封可確保防止馬達及軸承被化學氣體浸蝕，且泵浦運轉時，化學氣體經由延伸板及馬達底座之間的氣孔排出。
2. 以C型扣環固定葉輪，故可防止葉輪轉動時產生之徑向移動或鬆脫。
3. 泵浦入口管可加長，方便抽取桶槽較深之化學藥液，並可在入口管處直接加裝底閥。
4. 泵浦模具化生產，可依不同藥液性質選配不同之泵體材質 (FRPP、CFRPP、CPVC、PVDF)，機體重量較市面上同等產品輕盈，安裝方便，安全性大大提升。
5. 採用高效率鋁合金馬達，絕緣等級F級，適用於一般條件及各種化學環境下使用。
6. 本泵浦可無水空運轉使用。

KDV SERIES FEATURES:

1. Dry vapor seal can ensure to avoid motors and bearings from being etched by chemical gas. While a pump is operating, chemical gas through pores between the extended boards and the frame of motor is exhausted.
2. Because of the C-Clip, it can prevent the impeller from moving and losing during the operation.
3. The in-outlet of pump can be extended so that it becomes more convenient to draw the chemical solution from a tank.
4. Pumps are produced with standardized models and the materials of pump body are chosen depending on the mechanical solution (FRPP、CFRPP、CPVC、PVDF). The weight of pump compares with others in the market is lighter. Moreover, it is assembled easily and safely.
5. With highly effective aluminum motor and insulation class F, vertical pumps apply in normal situation and all kinds of environments.
6. Pumps can be operated in dry running without water.

NO	名稱 DESCRIPTION	材質 MATERIAL	NO	名稱 DESCRIPTION	材質 MATERIAL
1	馬達 Motor	FC / AL	22	馬達連接座 Motor Spacer	FRPP
2	軸心鍵 Shaft Key	SUS	23	C型扣環 C-Clip	FRPP/CFRPP/CPVC PVDF
3	液封陶瓷 Ceramic	FRPP/CFRPP/CPVC PVDF/CERAMIC	24	液封座 Vapor Seal Seat	FRPP/CFRPP/CPVC PVDF
3-1	陶瓷O環 Ceramic O-ring	EPDM/VITON	25	液封座O環 Vapor Seal Seat O-ring	NBR/EPDM/VITON
4	液封陶瓷O環 Vapor Seal O-ring	NBR/EPDM/VITON	26	陶瓷墊圈 Ceramic Gasket	NBR/EPDM/VITON
5	液封 Vapor Seal	NBR/EPDM/VITON	27	陶瓷 Ceramic	CERAMIC
6	軸套螺絲 Shaft Sleeve Screw	SUS	28	油封 Oil Seal	NBR/VITON
7	軸心套筒 Shaft Sleeve	FRPP/CFRPP/CPVC PVDF/SUS	29	液封座 Vapor Seal Seat	SUS
8	主體 Main Body	FRPP/CFRPP/CPVC PVDF/SUS	30	軸心套筒O環 Shaft Sleeve O-ring	VITON
8-1	主體O環 Main Body O-ring	NBR	31	主體墊片 Main Body Packing	EPDM/VITON/PTFE
9	主體螺絲 Main Body Screw	SUS	32	法蘭墊片 Flange Packing	EPDM/VITON
9-1	主體螺絲蓋 Main Body Screw Cap	NBR	33	法蘭墊片內襯 Flange Gasket	PTFE
10	排放螺絲墊片 Release Screw Packing	EPDM/VITON	34	法蘭 Flange	SUS
11	排放螺絲 Release Screw	PVC	35	法蘭固定螺絲 Flange Fasten Bolt	SUS
12	前封蓋螺絲 Front Cover Screw	SUS	36	葉輪固定套 Impeller Fixed sleeve	SUS
13	葉輪管O環 Impeller O-ring	NBR/EPDM/VITON	37	葉輪固定套O環 Impeller Fixed sleeve O-ring	EPDM/VITON/PFA
14	葉輪 Impeller	FRPP/CFRPP/CPVC/PVDF SUS	38	出口螺帽 Discharge Nut	PP/CPVC/PVDF
15	葉輪螺母O環 Impeller Nut O-ring	NBR/EPDM/VITON	39	出口由任套管 Discharge Union	PP
16	葉輪螺母 Impeller Nut	FRPP/CFRPP/CPVC/PVDF SUS	39-1	出口由任O環 Discharge Union O-ring	NBR/EPDM/VITON
16-1	葉輪螺母彈簧華司 Impeller Nut Spring	SUS	40	出口管 Discharge Pipe	PP/CPVC/PVDF
16-2	葉輪螺母墊片 Impeller Nut Packing	TEFLON	40-1	出口管O環 Discharge Pipe O-ring	NBR/EPDM/VITON
16-3	葉輪螺母華司 Impeller Nut Washer	SUS	41	C型扣環 C-ring	SUS
17	前封蓋O環 Front Cover O-ring	NBR/EPDM/VITON	42	前蓋壓板 Front Cover Pressing Plate	PP/CPVC/PVDF
18	前封蓋 Front Cover	FRPP/CFRPP/CPVC PVDF/SUS	43	出入口小O環 Discharge Upper O-ring	NBR/EPDM/VITON
19	排氣閥 Air Release Valve	FRPP/CFRPP/CPVC PVDF	44	活動法蘭 Movable Flange	FRPP
20	排氣閥墊片 Air Release Valve Packing	NBR/EPDM/VITON	45	出入口大O環 Discharge Lower O-ring	NBR/EPDM/VITON
21	馬達螺絲 Motor Screw	SUS	46	法蘭固定器 Flange Fasten Screw	FRPP

KD series

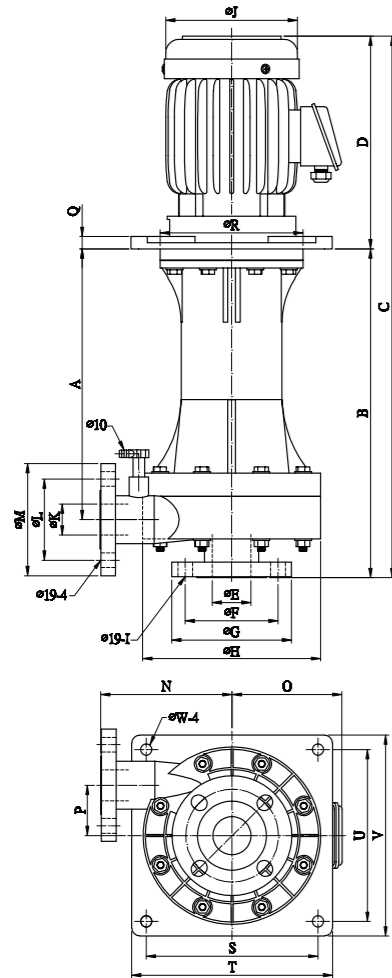

KD-B series

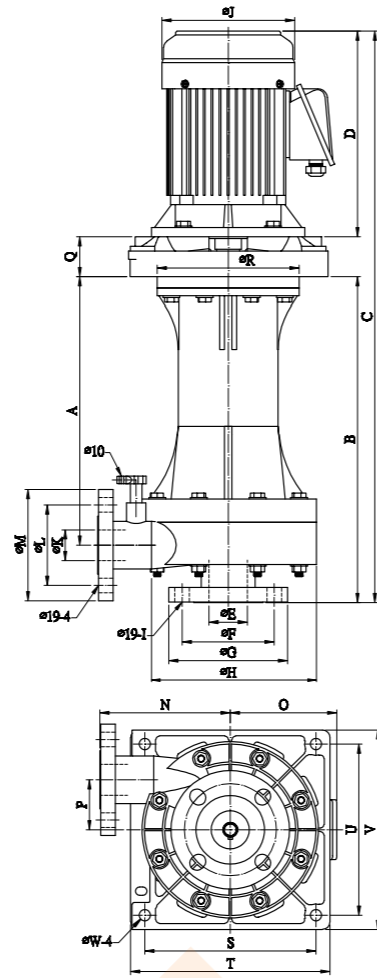

MODEL	A	B	C	D	E	F	G	H	I	J	K	L	M	N	O	P	Q	R	S	T	U	V	W
KD-41VK-1	353	423	698	275	50	120	155	230	4	170	40	105	145	170	142	65	16	185	222	260	222	260	15
KD-42VK-2	353	423	751	328	50	120	155	230	4	202	40	105	145	170	156	65	16	185	222	260	222	260	15
KD-42VK-3	353	423	751	328	50	120	155	230	4	202	40	105	145	170	156	65	16	185	222	260	222	260	15
KD-50VP-3	352	427	790	363	65	130	175	260	4	202	50	120	155	170	177	65	16	185	222	260	222	260	15
KD-50VK(P)-5	352	427	790	363	65	130	175	260	4	243	50	120	155	200	177	65	16	185	222	260	222	260	15
KD-65VK-5	352	427	790	363	80	150	190	260	8	243	65	140	175	200	177	65	16	185	222	260	222	260	15
KD-65VK(P)-7.5	352	427	862	435	80	150	190	260	8	285	65	140	175	200	212	65	20	185	300	350	300	350	18
KD-65VK(P)-10	352	427	862	435	80	150	190	260	8	285	65	140	175	200	212	65	20	185	300	350	300	350	18
KD-41VK-1-B	353	423	743	268	50	120	155	230	4	173	40	105	145	165	135	68	52	185	222	260	222	260	15
KD-42VK-2-B	353	423	785	310	50	120	155	230	4	195	40	105	145	165	150	68	52	185	222	260	222	260	15
KD-42VK-3-B	353	423	785	310	50	120	155	230	4	195	40	105	145	165	150	68	52	185	222	260	222	260	15
KD-50VP-3-B	352	427	789	310	65	130	175	260	4	195	50	120	155	195	150	65	52	185	222	260	222	260	15
KD-50VK(P)-5-B	352	427	819	340	65	130	175	260	4	195	50	120	155	195	150	65	52	185	222	260	222	260	15
KD-65VK-5-B	352	427	819	340	80	150	190	260	8	195	65	140	175	198	150	64	52	185	222	260	222	260	15
KD-65VK(P)-7.5-B	352	427	844	364	80	150	190	260	8	270	65	140	175	198	205	64	53	185	300	350	300	350	18
KD-65VK(P)-10-B	352	427	844	364	80	150	190	260	8	270	65	140	175	198	205	64	53	185	300	350	300	350	18

KDH series

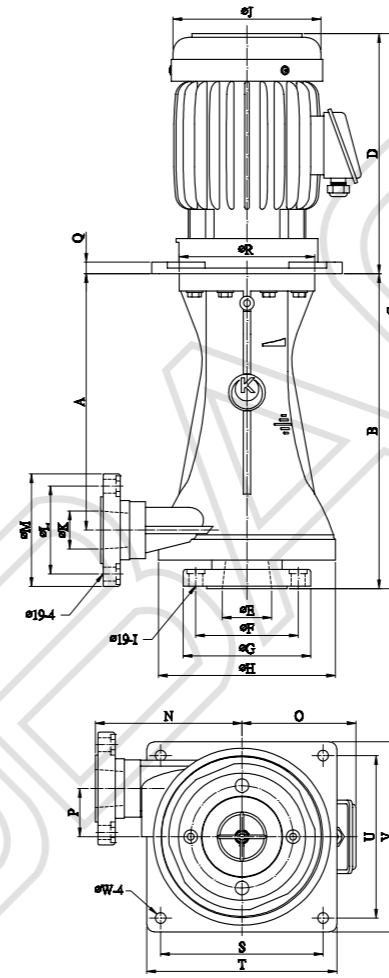

KDH-B series

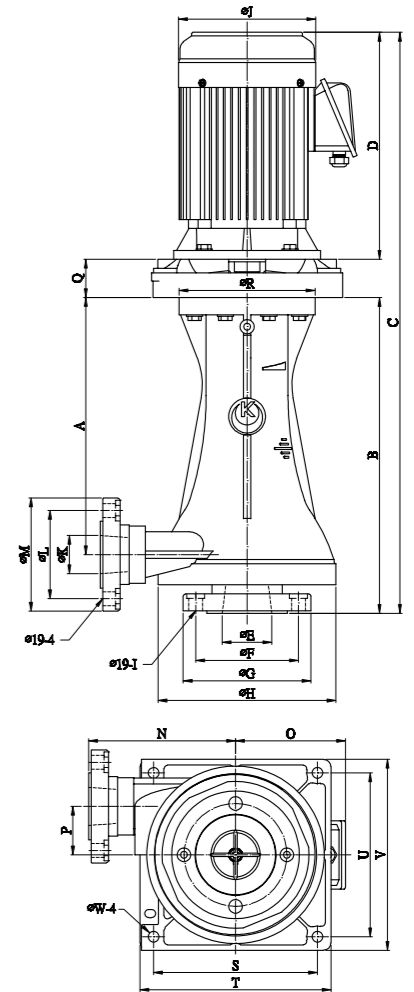

MODEL	A	B	C	D	E	F	G	H	I	J	K	L	M	N	O	P	Q	R	S	T	U	V	W
KDH-50VK(P)-3	350	430	758	328	65	140	174	242	4	202	50	120	154	200	156	66	16	185	222	260	222	260	15
KDH-50VK(P)-5	350	430	793	363	65	140	174	242	4	243	50	120	154	200	177	66	16	185	222	260	222	260	15
KDH-65VK-7.5	345	429	864	435	80	149	189	263	8	285	65	139	174	202	212	65	20	185	300	350	300	350	18
KDH-65VK(P)-7.5-H	345	429	864	435	80	149	189	263	8	285	65	139	174	202	212	65	20	185	300	350	300	350	18
KDH-65VP-10-H	345	429	864	435	80	149	189	263	8	285	65	139	174	202	212	65	20	185	300	350	300	350	18
KDH-50VK(P)-3-B	350	430	791	310	65	140	174	242	4	195	50	120	154	200	150	66	52	185	222	260	222	260	15
KDH-50VK(P)-5-B	350	430	822	340	65	140	174	242	4	195	50	120	154	200	150	66	52	185	222	260	222	260	15
KDH-65VK-7.5-B	345	429	846	364	80	149	189	263	8	270	65	139	174	202	205	65	53	185	300	350	300	350	18
KDH-65VK(P)-7.5-HB	345	429	846	364	80	149	189	263	8	270	65	139	174	202	205	65	53	185	300	350	300	350	18
KDH-65VP-10-HB	345	429	846	364	80	149	189	263	8	270	65	139	174	202	205	65	53	185	300	350	300	350	18

KDS series

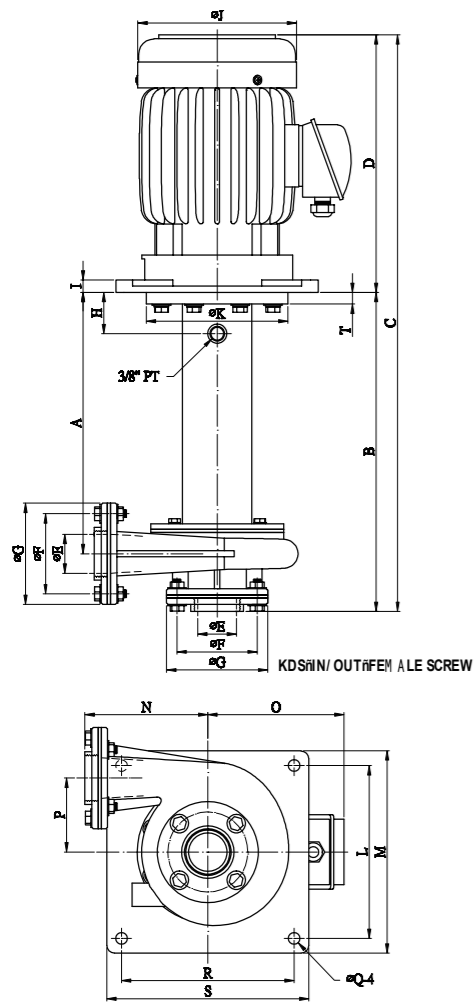

KP series

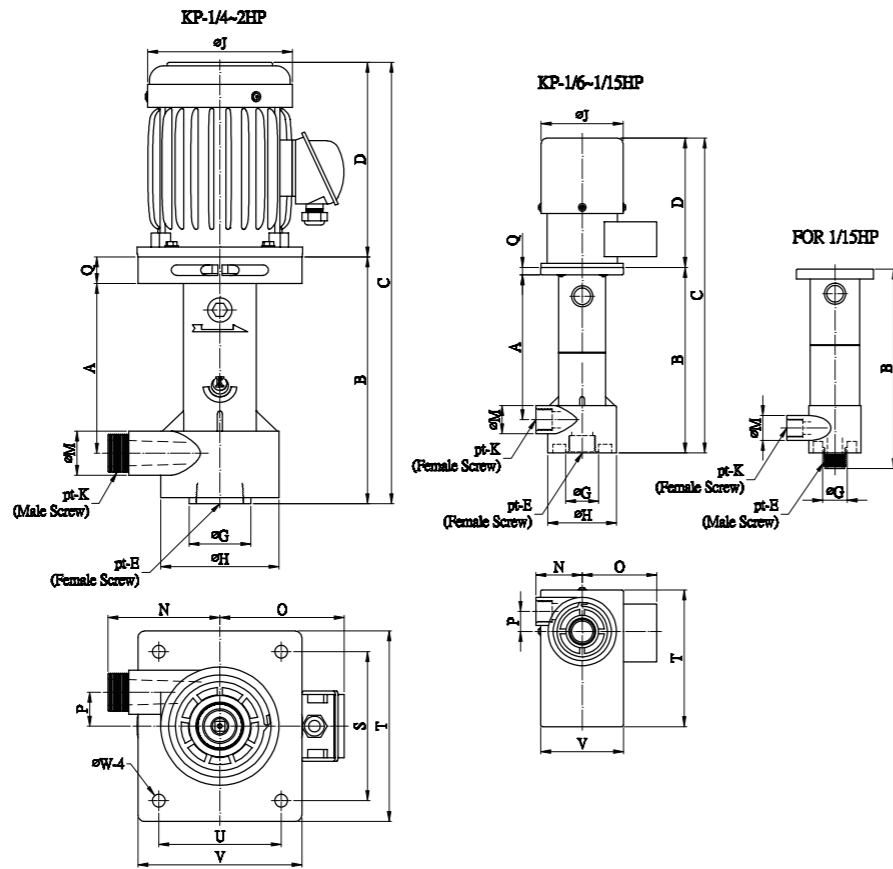

KPT series

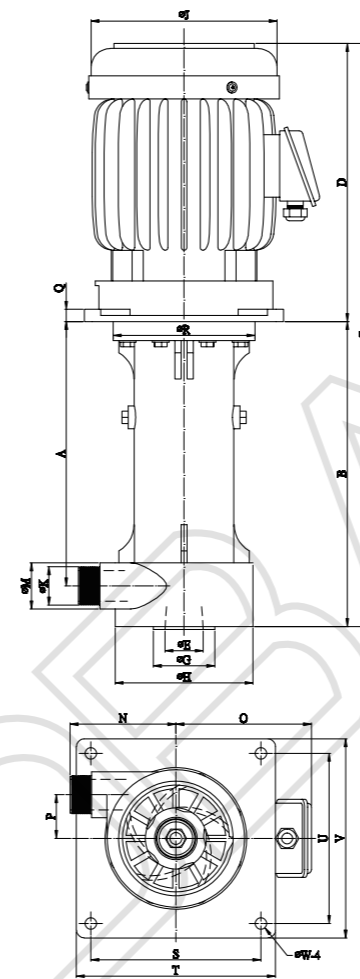

KPT-B series

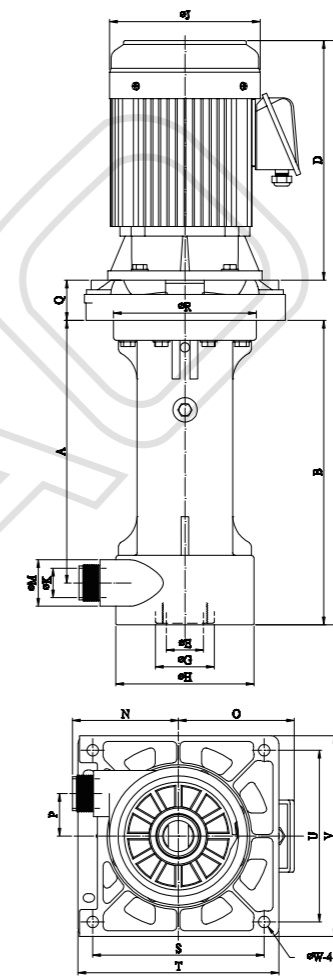

KDV series

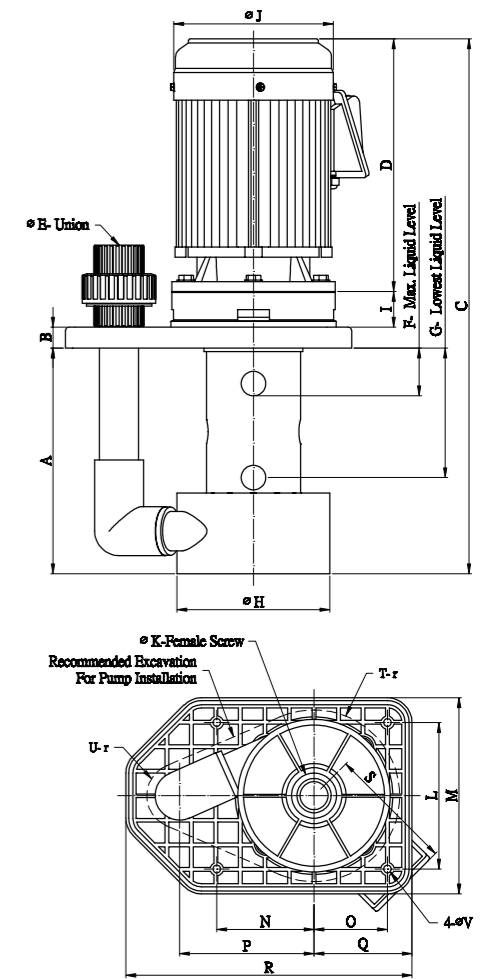

MODEL	A	B	C	D	E	F	G	H	I	J	K	L	M	N	O	P	Q	R	S	T	U	V	W	
KDS-25VK-1/2	235	300	536	236	25	64	78	53	12	175		180	235	119	150	62	15	150	235	15				
KDS-40VK(P)-16	238	305	539	234	40	91	120	51	12	175		180	235	140	150	70	15	180	235	16				
KDS-40VK(P)-26	238	305	539	234	40	91	120	51	12	175		180	235	140	150	70	15	180	235	16				
KDS-50VK(P)-36	336	410	741	331	50	103	130	53	16	204	182	222	260	158	175	95	15	222	260	16				
KDS-50VK(P)-56	336	410	778	368	50	103	130	53	16	234	182	222	260	158	182	95	15	222	260	16				
KP-15VK-1/15	180	240	402	162	20		30	63		99	15	30	56	70	16	12				141		93		
KP-20VK(P)-1/6	175	224	380	156	25		40	83		99	20	34	56	90	24	9				165		100		
KP-20VK-1/4	245	308	530	222	25		42	110		143	20	35	99	137	35	17				150	182	150	182	10
KP-20VK(P)-1/3	245	308	530	222	25		42	110		143	20	35	99	137	35	17				150	182	150	182	10
KP-25VK-1/2	205	298	533	235	40		75	143		175	25	49	111	150	41	32				180	230	148	198	15
KP-25VP-16	205	298	533	235	40		75	143		175	40	53	111	150	41	32				180	230	148	198	15
KP-40VK(P)-16	205	315	550	235	50		75	143		175	40	53	135	150	41	32				180	230	148	198	15
KP-40VK(P)-26	205	315	637	322	50		75	143		175	40	53	135	150	41	32				180	230	148	198	15

MODEL	A	B	C	D	E	F	G	H	I	J	K	L	M	N	O	P	Q	R	S	T	U	V	W
KPT-40VK(P)-26	345	398	726	328	50		76.5	180		200	40	60	138	156	57	16	185	222	260	222	260	15	
KPT-40VK(P)-36	345	398	726	328	50		76.5	180		200	40	60	138	156	57	16	185	222	260	222	260	15	
KPT-40VK(P)-56	345	398	767	369	50		76.5	180		238	40	60	138	177	57	16	185	222	260	222	260	15	
KPT-50VP-36	345	398	726	328	50		76.5	180		200	40	60	138	156	57	16	185	222	260	222	260	15	
KPT-50VP-56	345	398	783	385	50		76.5	180		238	50	60	138	177	57	16	185	222	260	222	260	15	
KPT-40VK(P)-2-B	345	398	760	310	50		76.5	180		195	40	60	138	150	55	52	185	222	260	222	260	15	
KPT-40VK(P)-3-B	345	398	760	310	50		76.5	180		195	40	60	138	150	55	52	185	222	260	222	260	15	
KPT-40VK(P)-5-B	345	398	790	340	50		76.5	180		195	40	60	138	150	55	52	185	222	260	222	260	15	
KPT-50VP-3-B	345	398	760	310	50		76.5	180		195	50	60	138	150	55	52	185	222	260	222	260	15	
KPT-50VP-5-B	345	398	790	340	50		76.5	180		195	50	60	138	150	55	52	185	222	260	222	260	15	
KDV-32VK-16	270	25	581	244	32	60	165	154	42	156	48	148	198	99	75	141	100	298	120	85	35	10	
KDV-40VK-26	276	25	654	309	40	58	158	187	44	195	50	179	240	119	90	165	120	350	155	105	40	10	
KDV-40VP-36	276	25	654	309	40	58	158	187	44	195	50	179	240	119	90	165	120	350	155	105	40	10	
KDV-40VK-46	275	25	691	345	40	53	153	208	46	195	50	220	280	140	115	180	145	390		115	40	9	
KDV-40VK-56	275	25	691	345	40	53	153	208	46	195	50	220	280	140	115	180	145	390		115	40	9	
KDV-50VK-7.56	312	35	766	365	50	56	175	249	54	260	65	280	342	160	140	231	170	472		135	45	12	
KDV-50VK-106	312	35	766	365	50	56	175	249	54	260	65	280	342	160	140	231	170	472		135	45	12	

泵浦典型應用例

下列圖示為立式無軸泵浦之典型應用例，並可依特殊應用做組合。

PUMP APPLICATION EXAMPLES

The following is the examples of vertical and sealless pump, which can be combined according to special requirements.

▽ 使用於廢棄清洗塔 For cleaning waste gas.

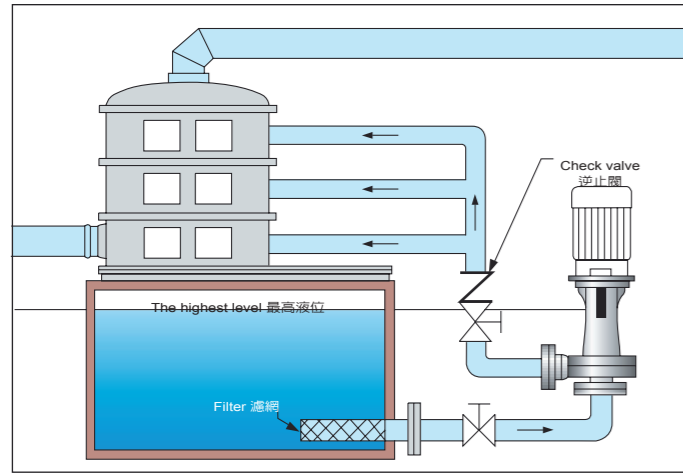

▽ 反應槽或過濾壓縮機用 Application for cleaning tower.

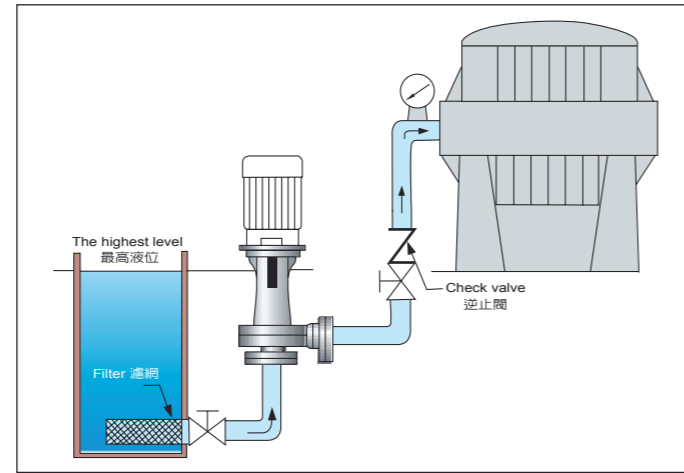

▽ 泵浦裝置桶外，配合過濾器使用 Installed outside tank for filter.

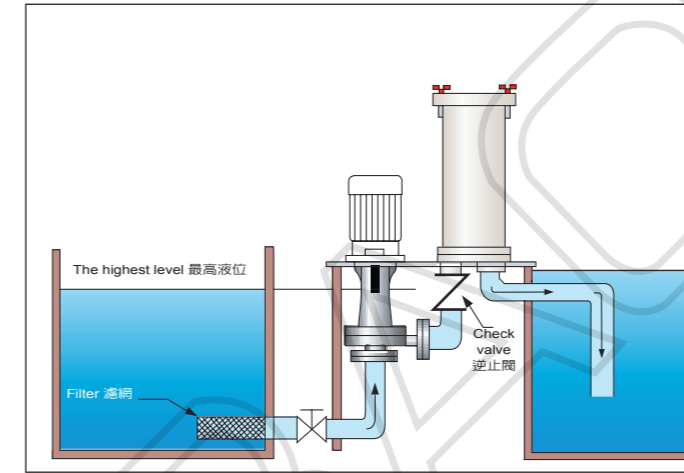

▽ 泵浦裝置桶內，配合過濾器使用 Installed inside tank for filter.

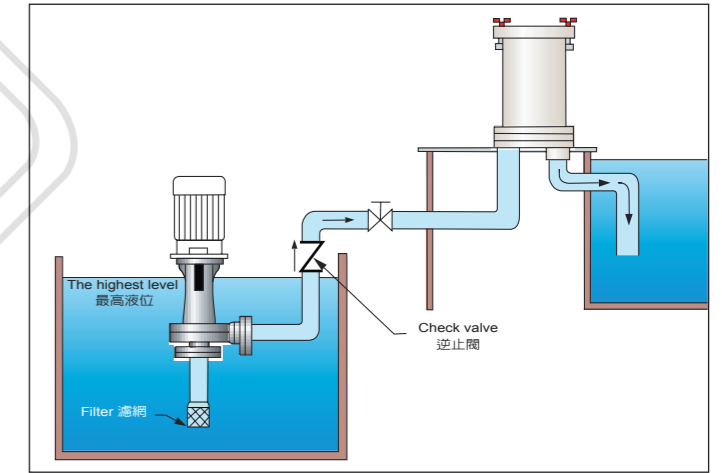

▽ 塗料泵浦蝕刻 Application spray pump etching.

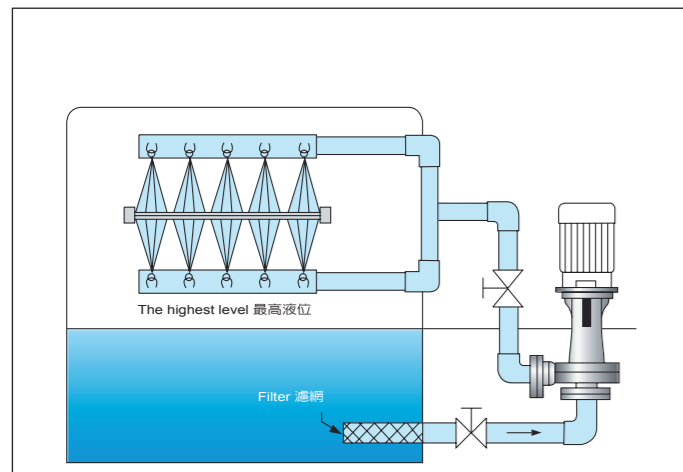

▽ 安裝於桶外 Installed outside of tank.

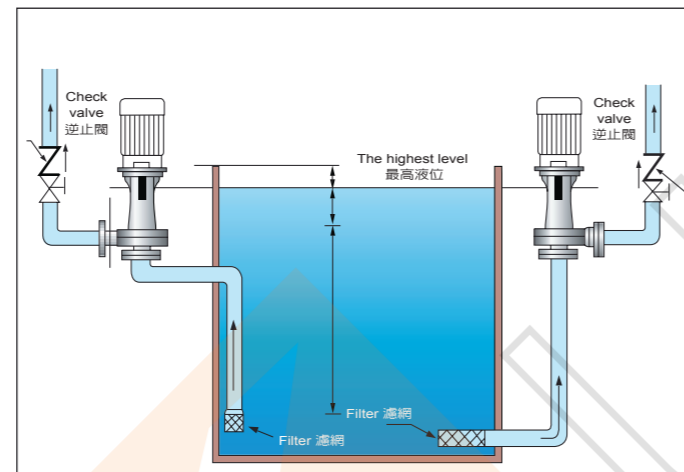

▽ 使用於熱交換器 For heat exchanger.

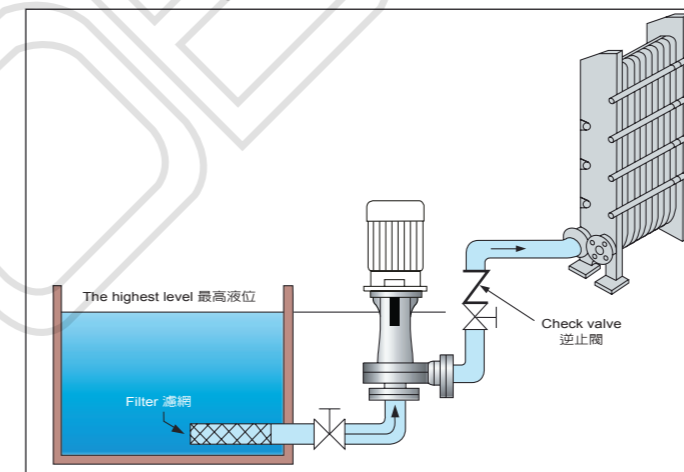

▽ 警告：不正確使用 Warning: Wrong application.

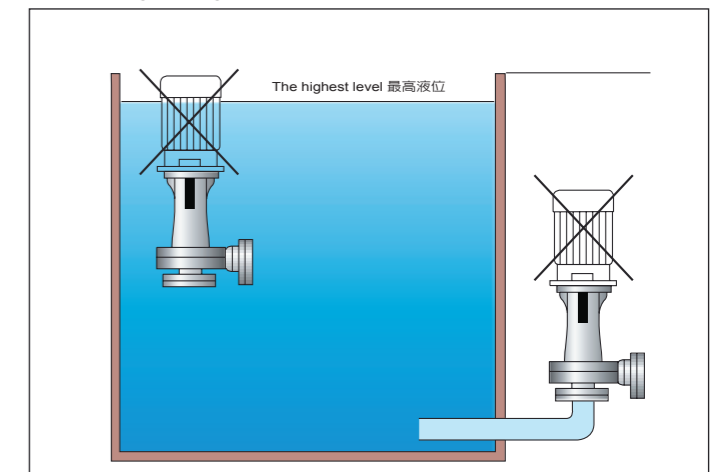

▽ 液體交換之特殊應用 Special application for liquid interchange.

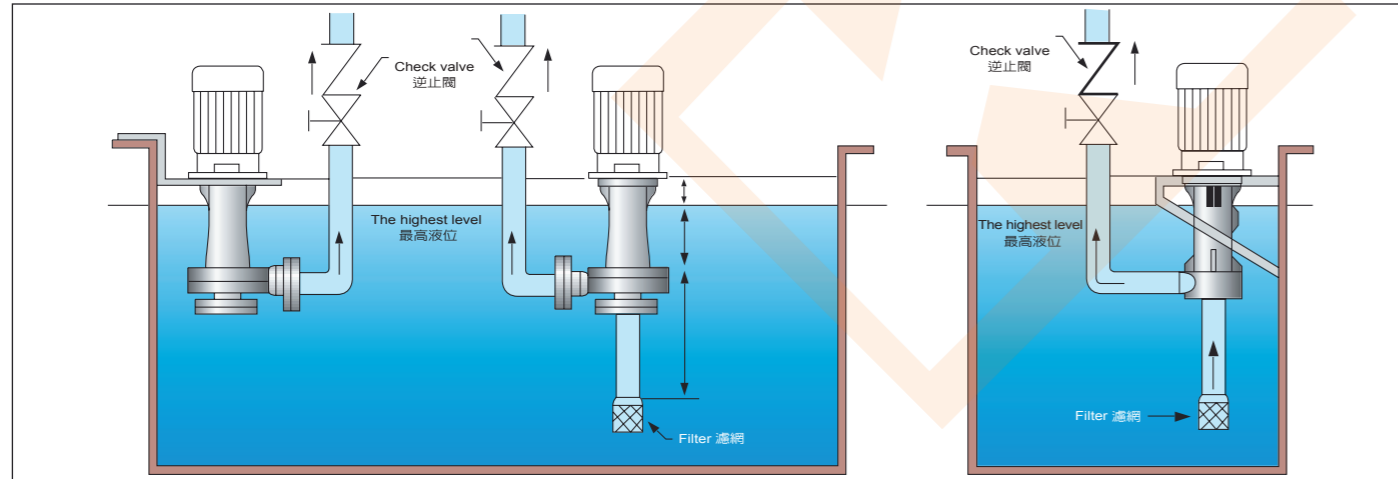

使用須知：

- 若使用於化學工廠或存有揮發性氣體之環境使用，必
 需選擇安全增防爆Eg3或D2g4型馬達。
- 入口管處需加裝濾網，以防止吸入異物，造成泵浦損口
 壞。
- 出口配管若高於馬達時，需於液面最高點加裝逆止
 閥，以防止馬達損壞。
- 不同類型之化學藥液混合混合在一起，會引起化學反
 應，甚至產生高熱，而使泵浦受損，因此，不要同
 一泵浦輸送不同化學藥液。

Important Instruction:

- If pump is used in chemical factory or in volatility environment, you have to use explosion-proof motor. (Eg3 or D2g4 type)
- Protect pump from sucking foreign matter, please install strainer on the inlet of pump.
- If outlet pipe is above motor, you have to install check valve at the highest liquid level to protect motor.
- Mixing different types of chemical liquid will produce extreme heat to damage pump. Please transit one particular chemical liquid within one pump.